

8-Bit Microcontroller for Monitor

Features

- 40 pin DIP & 42 pin SDIP package
- Operating Voltage Range: 4.5V to 5.5V
- CMOS technology for low power consumption
- Crystal oscillator or ceramic resonator* available
- 6502 8-bit CMOS CPU core
- 8MHz operation of frequency
- 4/8/12/16/24K bytes ROM are available
- 256 bytes of RAM (which stores EDID for DDC1/2B)
- One 8-bit pre-loadable base timer
- 14 channels of 8 bit PWM outputs:
 - 6 channel with 5V open drain and 8 channel with 12V open drain
- 2 channel A/D converters with 6-bit resolution
- 24 bi-directional I/O port pins and 1 I/P pin
- Hsync/Vsync signal processor
- Hardware sync signals polarity & freq. evaluator
- Built-In I²C bus interface
- Supporting VESA DDC1/2B function
- Six-interrupt sources
 - INTV (Vsync INT)
 - INTE (External INT with rising edge trigger)
 - INTMR (Timer INT)
 - INTA (Slave Address Matched INT)
 - INTD (Shift Register INT)
 - INTS (SCL GO-LOW INT)
- Hardware watch-dog timer function

General Description

NT6861 is a monitor component μ C for auto-sync and digital controlled applications. It contains a 6502 8-bit CPU core, 256 bytes of RAM used as working RAM and stack area, 24K bytes of ROM maximum for programming, 14-channel 8-bit PWM D/A converters, 2-channel A/D converters for key detection saving I/O pins, one 8 bit pre-loadable base timer, internal Hsync and Vsync signals processor providing mode detection, watch-dog timer preventing system from abnormal operation, and an I²C bus interface.

Users can store EDID data in the 128 bytes of RAM for DDC1/2B, so that users can save the cost of dedicated EEPROM for EDID. Half frequency output function can save external one-shot circuit. All of these designs create savings in component costs.

* The frequency deviation of ceramic resonator has +/- 6% maximum.

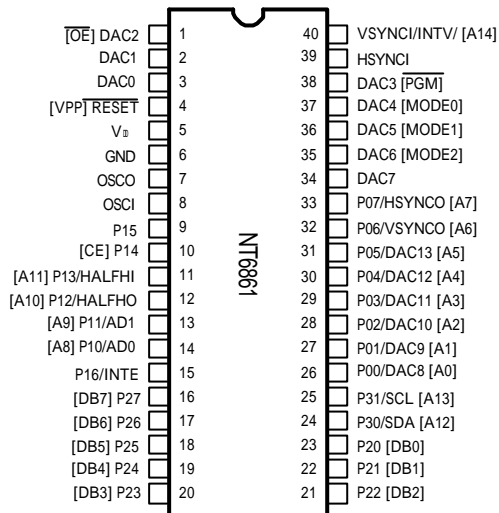
Pin Configuration

* []: OTP Mode

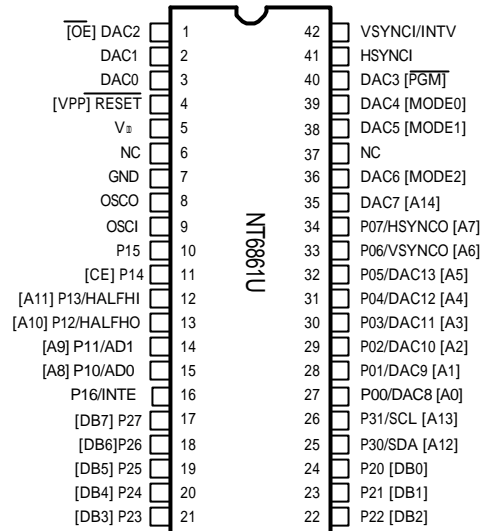

* []: OTP Mode

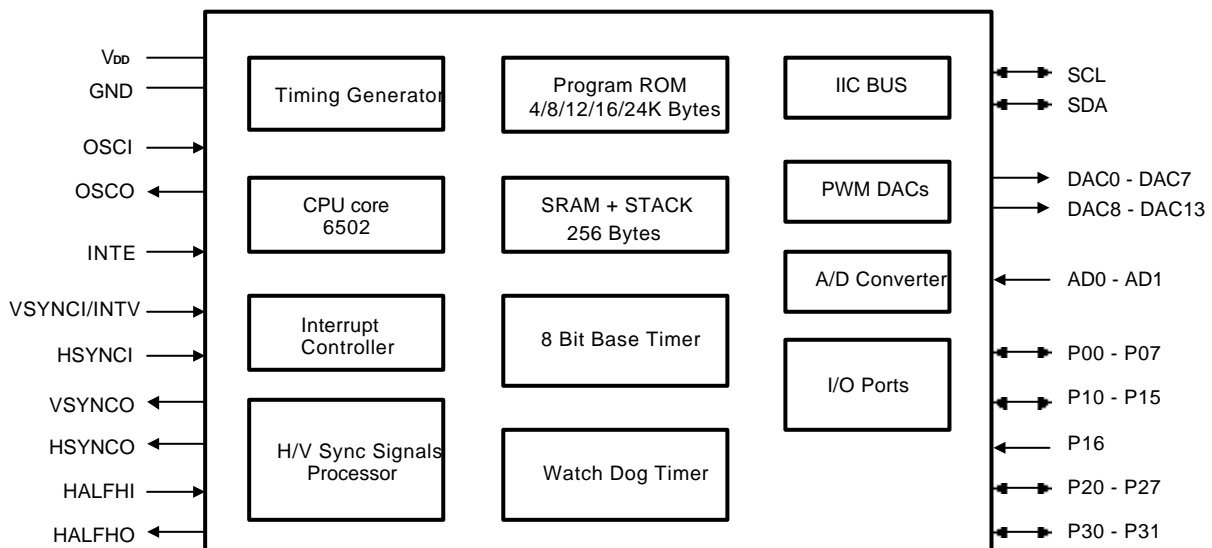
Block Diagram

Pin Descriptions

Pin No.		Designation	Reset Init.	I/O	Description
40 Pin	42 Pin				
1	1	DAC2		O	Open drain 12V, D/A converter output 2
2	2	DAC1		O	Open drain 12V, D/A converter output 1
3	3	DAC0		O	Open drain 12V, D/A converter output 0
4	4	$\overline{\text{RESET}}$		I	Schmitt trigger input pin, low active reset*
5	5	V _{DD}		P	Power
6	7	GND		P	Ground
7	8	OSCO		O	Crystal OSC output
8	9	OSCI		I	Crystal OSC input
9	10	P15		I/O	Bi-directional I/O pin
10	11	P14		I/O	Bi-directional I/O pin
11	12	P13/HALFHI	P13	I/O	Bi-directional I/O pin, shared with half hsync input
12	13	P12/HALFHO	P12	I/O	Bi-directional I/O pin, shared with half hsync output
13	14	P11/AD1	P11	I/O	Bi-directional I/O pin, shared with A/D converter channel 1 input
14	15	P10/AD0	P10	I/O	Bi-directional I/O pin, shared with A/D converter channel 0 input
15	16	P16/INTE	P16	I	Schmitt trigger input pin with internal pull high, shared with external Rising-edge trigger interrupt
16 - 23	17 - 24	P27 - P20		I/O	Bi-directional I/O pin, push-pull structure with high current drive/sink capability

* This $\overline{\text{RESET}}$ pin must be pulled high by external pulled-up resistor (5K Ω suggestion), or it will stay low voltage to reset system all the time.

Pin Descriptions (continued)

Pin NO.		Designation	Reset Init.	I/O	Description
40 Pin	42 Pin				
24	25	P30/SDA	P30	I/O	Open drain 5V Bi-direction I/O pin P30, shared with SDA pin of I ² C bus schmitt trigger buffer
25	26	P31/SCL	P31	I/O	Open drain 5V Bi-direction I/O pin P31, shared with SCL pin of I ² C bus schmitt trigger buffer
26	27	P00/DAC8	P00	I/O	Bi-directional I/O pin, shared with open drain 5V D/A converter output 8
27	28	P01/DAC9	P01	I/O	Bi-directional I/O pin, shared with open drain 5V D/A converter output 9
28	29	P02/DAC10	P02	I/O	Bi-directional I/O pin, shared with open drain 5V D/A converter output 10
29	30	P03/DAC11	P03	I/O	Bi-directional I/O pin, shared with open drain 5V D/A converter output 11
30	31	P04/DAC12	P04	I/O	Bi-directional I/O pin, shared with open drain 5V D/A converter output 12
31	32	P05/DAC13	P05	I/O	Bi-directional I/O pin, shared with open drain 5V D/A converter output 13
32	33	P06/VSYNCO	P06	I/O	Bi-directional I/O pin, shared with vsync out
33	34	P07/HSYNCO	P07	I/O	Bi-directional I/O pin, shared with hsync out
34	35	DAC7		O	Open drain 12V, D/A converter output
35	36	DAC6		O	Open drain 12V, D/A converter output
36	38	DAC5		O	Open drain 12V, D/A converter output
37	39	DAC4		O	Open drain 12V, D/A converter output
38	40	DAC3		O	Open drain 12V, D/A converter output
39	41	HSYNCI		I	Debouncing & Schmitt trigger input pin for video horizontal sync signal, internal pull high, shared with composite sync input
40	42	VSYNCI/INTV	VSYNCI	I	Debouncing & Schmitt trigger input pin for video vertical sync signal, internally pull high, shared with external interrupt source
-	6	NC			
-	37	NC			

Functional Descriptions
1. 6502 CPU

The 6502 is an 8-bit CPU that provides 56 instructions, decimal and binary arithmetic, thirteen addressing modes, true indexing capability, programmable stack pointer with variable length stack, a wide selection of addressable memory, and interrupt input options.

The CPU clock cycle is 4MHz (8MHz system clock divided by 2). Refer to 6502 data sheet for more details.

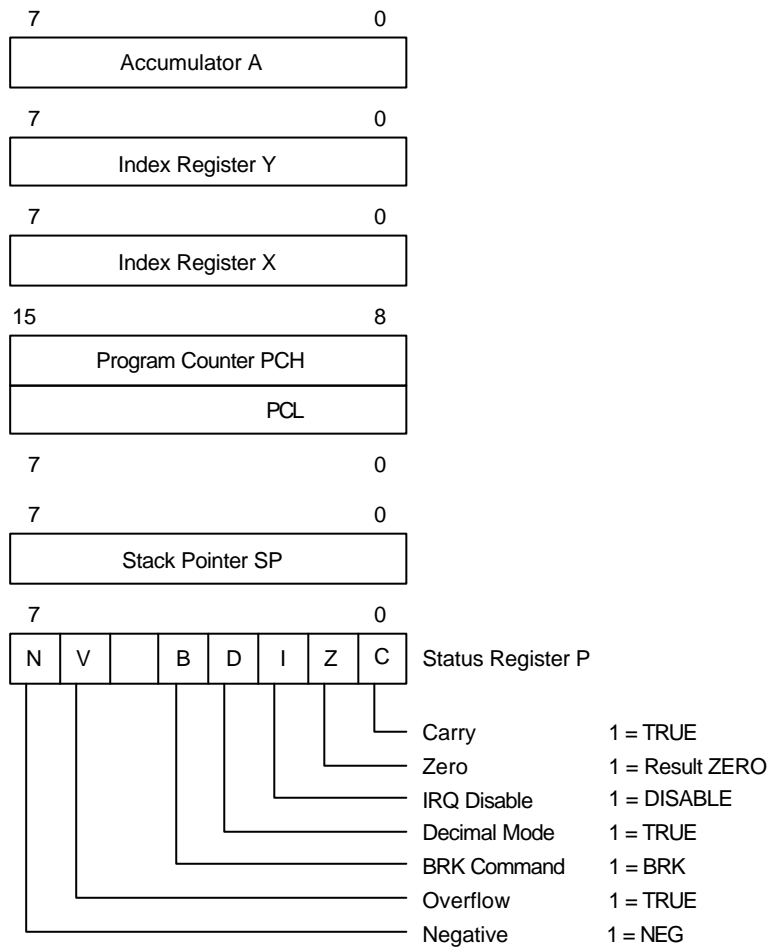

Figure 1. 6502 CPU Registers and Status Flags

2. Instruction set list

Instruction Code	Meaning	Operation
ADC	Add with carry	$A + M + C \rightarrow A, C$
AND	Logical AND	$A \cdot M \rightarrow A$
ASL	Shift left one bit	$C \leftarrow M7 \dots M0 \leftarrow 0$
BCC	Branch if carry clears	Branch on $C = 0$
BCS	Branch if carry sets	Branch on $C = 1$
BEQ	Branch if equal to zero	Branch on $Z = 1$
BIT	Bit test	$A \cdot M, M7 \rightarrow N, M6 \rightarrow V$
BMI	Branch if minus	Branch on $N = 1$
BNE	Branch if not equal to zero	Branch on $Z = 0$
BPL	Branch if plus	Branch on $N = 0$
BRK	Break	Forced Interrupt $PC+2 \downarrow PC \downarrow$
BVC	Branch if overflow clears	Branch on $V = 0$
BVS	Branch if overflow sets	Branch on $V = 1$
CLC	Clear carry	$0 \rightarrow C$
CLD	Clear decimal mode	$0 \rightarrow D$
CLI	Clear interrupt disable bit	$0 \rightarrow I$
CLV	Clear overflow	$0 \rightarrow V$
CMP	Compare accumulator to memory	$A - M$
CPX	Compare with index register X	$X - M$
CPY	Compare with index register Y	$Y - M$
DEC	Decrement memory by one	$M - 1 \rightarrow M$
DEX	Decrement index X by one	$X - 1 \rightarrow X$
DEY	Decrement index Y by one	$Y - 1 \rightarrow Y$
EOR	Logical exclusive-OR	$A \oplus M \rightarrow A$
INC	Increment memory by one	$M + 1 \rightarrow M$
INX	Increment index X by one	$X + 1 \rightarrow X$
INY	Increment index Y by one	$Y + 1 \rightarrow Y$

Instruction set list (continued)

Instruction Code	Meaning	Operation
JMP	Jump to new location	$(PC+1) \rightarrow PCL, (PC+2) \rightarrow PCH$
JSR	Jump to subroutine	$PC + 2 \downarrow, (P+1) \rightarrow PCL, (PC+2) \rightarrow PCH$
LDA	Load accumulator with memory	$M \rightarrow A$
LDX	Load Index register X with memory	$M \rightarrow X$
LDY	Load Index register Y with memory	$M \rightarrow Y$
LSR	Shift right one bit	$0 \rightarrow M7 \dots M0 \rightarrow C$
NOP	No operation	No operation (2 cycles)
ORA	Logical OR	$A + M \rightarrow A$
PHA	Push accumulator on stack	$A \downarrow$
PHP	Push status register on stack	$P \downarrow$
PLA	Pull accumulator from stack	$A \uparrow$
PLP	Pull status register from stack	$P \uparrow$
ROL	Rotate left through carry	$C \leftarrow M7 \dots M0 \leftarrow C$
ROR	Rotate right through carry	$C \rightarrow M7 \dots M0 \rightarrow C$
RTI	Return from interrupt	$P \uparrow, PC \uparrow$
RTS	Return from subroutine	$PC \uparrow, PC+1 \rightarrow PC$
SBC	Subtract with borrow	$A - M - C \rightarrow A, C$
SEC	Set carry	$1 \rightarrow C$
SED	Set decimal mode	$1 \rightarrow D$
SEI	Set interrupt disable status	$1 \rightarrow I$
STA	Store accumulator in memory	$A \rightarrow M$
STX	Store index register X in memory	$X \rightarrow M$
STY	Store index register Y in memory	$Y \rightarrow M$
TAX	Transfer accumulator to index X	$A \rightarrow X$
TAY	Transfer accumulator to index Y	$A \rightarrow Y$
TSX	Transfer stack pointer to index X	$S \rightarrow X$
TXA	Transfer index X to accumulator	$X \rightarrow A$
TXS	Transfer index X to stack Pointer	$X \rightarrow S$
TYA	Transfer index Y to accumulator	$Y \rightarrow A$

* Refer to 6502 programming data book for more details.

3. RAM: 256 X 8 bits

256 X 8-bit SRAM is used for data memory and stack. The RAM addressing range is from \$0080 to \$017F. From \$0100 to \$017F is used as the EDID data buffer when activating DDC1/2B mode transmission. The contents of RAM are undetermined at power-up and are not affected by system reset. Software programmers can allocate stack area in the RAM by setting stack pointer register S. Because the 6502 default stack pointer is \$01FF, programmers must set register S to FFH when starting the program, so the stack area will map \$01FF - \$0180 to \$00FF - \$0080.

```
as;   LDX   #$FF
      TXS
```

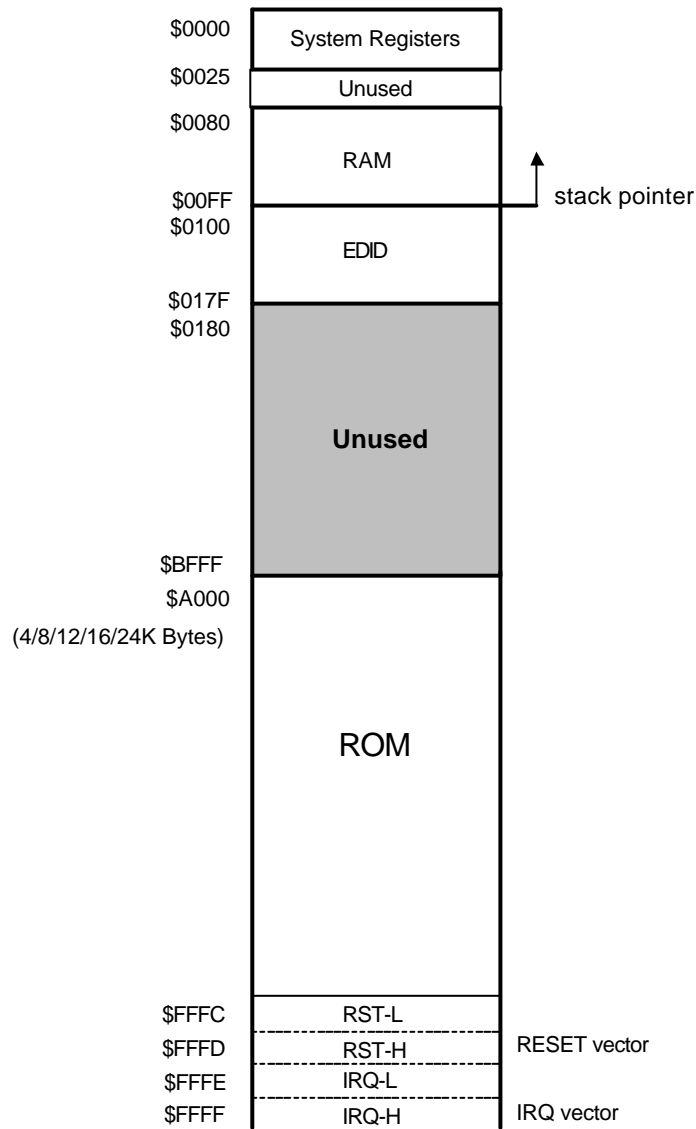

4. System Registers

Addr.	Register	INIT	Bit7	Bit6	Bit5	Bit4	Bit3	Bit2	Bit1	Bit0	
\$0000	PT0	FFH	P07	P06	P05	P04	P03	P02	P01	P00	RW
\$0001	PT1	7FH	-	P16	P15	P14	P13	P12	P11	P10	RW
\$0002	PT2DIR	FFH	$\overline{P27OE}$	$\overline{P26OE}$	$\overline{P25OE}$	$\overline{P24OE}$	$\overline{P23OE}$	$\overline{P22OE}$	$\overline{P21OE}$	$\overline{P20OE}$	W
\$0003	PT2	FFH	P27	P26	P25	P24	P23	P22	P21	P20	RW
\$0004	PT3	03H	-	-	-	-	-	-	P31	P30	RW
\$0005	MD CON	07H	-	-	-	-	-	-	S/C	MD1/2	R W
			-	-	-	-	\overline{INSEN}	\overline{HSEL}	S/C	MD1/2	
\$0006	HV CON	2FH	HCNTOV	VCNTOV	HSYNCI	VSYNCI	HPOLI	VPOLI	HPOLO	VPOLO	R W
\$0007	HCNT L	00H	HCL7	HCL6	HCL5	HCL4	HCL3	HCL2	HCL1	HCL0	R
\$0008	HCNT H	00H	-	-	-	-	HCH3	HCH2	HCH1	HCH0	R
\$0009	VCNT L	00H	VCL7	VCL6	VCL5	VCL4	VCL3	VCL2	VCL1	VCL0	R
\$000A	VCNT H	00H	-	-	-	-	VCH3	VCH2	VCH1	VCH0	R
\$000B	SYNCON	FFH	\overline{NOHALF}	\overline{ENHALF}	-	\overline{FRUN}	\overline{FRFREQ}	HALFPOL	\overline{ENH}	\overline{ENV}	W
\$000C	ENDAC	FFH	$\overline{ENAD1}$	$\overline{ENAD0}$	$\overline{ENDK13}$	$\overline{ENDK12}$	$\overline{ENDK11}$	$\overline{ENDK10}$	$\overline{ENDK9}$	$\overline{ENDK8}$	W
\$000D	AD0 REG	C0 H	\overline{CEND}	\overline{CSTA}	AD05	AD04	AD03	AD02	AD01	AD00	R W
\$000E	AD1 REG	00H	-	-	AD15	AD14	AD13	AD12	AD11	AD10	R
\$000F	IEX	00H	-	-	IEINTS	IEINTD	IEINTA	IEINTR	IEINTE	IEINTV	W

System Registers (continued)

Addr.	Register	INIT	Bit7	Bit6	Bit5	Bit4	Bit3	Bit2	Bit1	Bit0	
\$0010	IRQX	00H	-	-	IRQINTS	IRQINTD	IRQINTA	IRQINTR	IRQINTE	IRQINTV	R
\$0011	CLR FLG	00H	CLRHOV	CLRVOV	CLRINTS	CLRINTD	CLRINTA	CLRINTR	CLRINTE	CLRINTV	W
\$0012	CLR WDT	-	0	1	0	1	0	1	0	1	W
\$0013	II ADR	FFH	AR7	AR6	AR5	AR4	AR3	AR2	AR1	-	W
\$0014	II DAT	00H	SR7	SR6	SR5	SR4	SR3	SR2	SR1	SR0	RW
\$0015	II STS	08H	-	-	START START	STOP STOP	$\overline{\text{ENDDC}}$	TRX	RXAK	-	R W
\$0016	BT	00H	BT7	BT6	BT5	BT4	BT3	BT2	BT1	BT0	W
\$0017	BT CON	03H	-	-	-	-	-	-	TBS	$\overline{\text{ENBT}}$	W
\$0018	DACH0	80H	DKVL7	DKVL6	DKVL5	DKVL4	DKVL3	DKVL2	DKVL1	DKVL0	RW
\$0019	DACH1	80H	DKVL7	DKVL6	DKVL5	DKVL4	DKVL3	DKVL2	DKVL1	DKVL0	RW
\$001A	DACH2	80H	DKVL7	DKVL6	DKVL5	DKVL4	DKVL3	DKVL2	DKVL1	DKVL0	RW
\$001B	DACH3	80H	DKVL7	DKVL6	DKVL5	DKVL4	DKVL3	DKVL2	DKVL1	DKVL0	RW
\$001C	DACH4	80H	DKVL7	DKVL6	DKVL5	DKVL4	DKVL3	DKVL2	DKVL1	DKVL0	RW
\$001D	DACH5	80H	DKVL7	DKVL6	DKVL5	DKVL4	DKVL3	DKVL2	DKVL1	DKVL0	RW
\$001E	DACH6	80H	DKVL7	DKVL6	DKVL5	DKVL4	DKVL3	DKVL2	DKVL1	DKVL0	RW
\$001F	DACH7	80H	DKVL7	DKVL6	DKVL5	DKVL4	DKVL3	DKVL2	DKVL1	DKVL0	RW
\$0020	DACH8	80H	DKVL7	DKVL6	DKVL5	DKVL4	DKVL3	DKVL2	DKVL1	DKVL0	RW
\$0021	DACH9	80H	DKVL7	DKVL6	DKVL5	DKVL4	DKVL3	DKVL2	DKVL1	DKVL0	RW
\$0022	DACH10	80H	DKVL7	DKVL6	DKVL5	DKVL4	DKVL3	DKVL2	DKVL1	DKVL0	RW
\$0023	DACH11	80H	DKVL7	DKVL6	DKVL5	DKVL4	DKVL3	DKVL2	DKVL1	DKVL0	RW
\$0024	DACH12	80H	DKVL7	DKVL6	DKVL5	DKVL4	DKVL3	DKVL2	DKVL1	DKVL0	RW
\$0025	DACH13	80H	DKVL7	DKVL6	DKVL5	DKVL4	DKVL3	DKVL2	DKVL1	DKVL0	RW

Note: The line above a writable signal name indicate an active low signal
The dash line in these control register indicate an undefined bit
The address of control register from \$0026 to \$007F are not used.

5. Timing Generator

This block generates the system timing and control signal to be supplied to the CPU and on-chip peripherals. A crystal quartz, ceramic resonator, or an external clock signal provided to the OSC1 pin generates 8MHz system clock, (4 MHz for CPU), Although internal circuits have a feedback resistor and capacitor included, components may be externally added to ensure proper operation. The typical clock frequency is 8MHz. This frequency will affect the operation of on-chip peripherals whose operating frequency is based on the system clock .

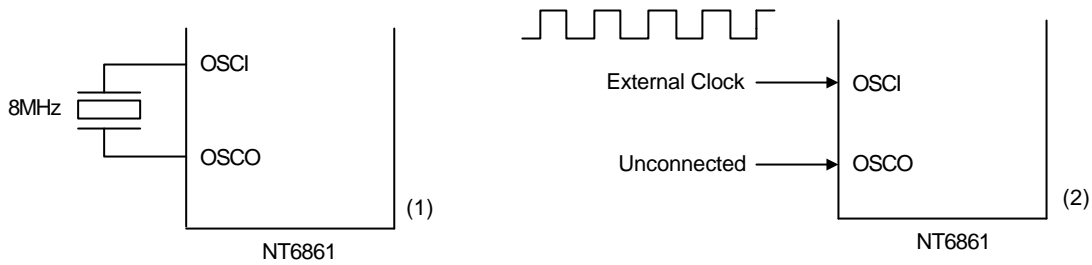

Figure 2. Oscillator Connections

6. A/D Converter

The analog to digital converter is a single 6-bit successive approximation converter. Analog voltage is supplied from external sources to the A/D input pins and the results of the conversion are stored in the 6-bit data latch registers (\$000D & \$000E). The A/D converter is controlled by the control bits in the A/D control register ENDAC. Refer to the A/D channel format table A/D input pins activation. A conversion is started by setting a '0' to the CONVERSION START bit (\overline{CSTA}) in the A/D control register (\$000D). This automatically sets the CONVERSION END bit (\overline{CEND}) to '1'. When a conversion has been finished, \overline{CEND} bit automatically clears to '0'. The A/D conversion data in the AD LATCH registers (\$000D & \$000E) is valid digital data.

The analog voltage to be measured should be stabled during the conversion operation. The variation should exceed 1/2 LSB for accuracy in measurement. Please refer Figure 3 for checking the linearity of A/D.

A/D Channel Format Table

$\overline{ENAD1}$	$\overline{ENAD0}$	P11 line	P10 line
0	0	AD1	AD0
0	1	AD1	P10
1	0	P11	AD0
1	1	P11	P10

A/D Channel Control Register

Addr.	Register	INIT	Bit7	Bit6	Bit5	Bit4	Bit3	Bit2	Bit1	Bit0	
\$000C	ENDAC	FFH	$\overline{\text{ENAD1}}$	$\overline{\text{ENAD0}}$	$\overline{\text{ENDK13}}$	$\overline{\text{ENDK12}}$	$\overline{\text{ENDK11}}$	$\overline{\text{ENDK10}}$	$\overline{\text{ENDK9}}$	$\overline{\text{ENDK8}}$	W
\$000D	AD0 REG	C0H	$\overline{\text{CEND}}$	$\overline{\text{CSTA}}$	AD05	AD04	AD03	AD02	AD01	AD00	R W
\$000E	AD1 REG	00H	-	-	AD15	AD14	AD13	AD12	AD11	AD10	R

Input Voltage	Digital Value
1.5	19 (\$13)
1.58	20 (\$14)
1.65	21 (\$15)
1.73	22 (\$16)
1.81	23 (\$17)
1.90	24 (\$18)
1.97	25 (\$19)
2.06	26 (\$1A)
2.14	27 (\$1B)

Input Voltage	Digital Value
2.22	28 (\$1C)
2.29	29 (\$1D)
2.37	30 (\$1E)
2.45	31 (\$1F)
2.53	32 (\$20)
2.61	33 (\$21)
2.68	34 (\$22)
2.76	35 (\$23)
2.84	36 (\$24)

Input Voltage	Digital Value
2.91	37 (\$25)
2.98	38 (\$26)
3.06	39 (\$27)
3.15	40 (\$28)
3.24	41 (\$29)
3.32	42 (\$2A)
3.40	43 (\$2B)
3.47	44 (\$2C)
3.55	45 (\$2D)

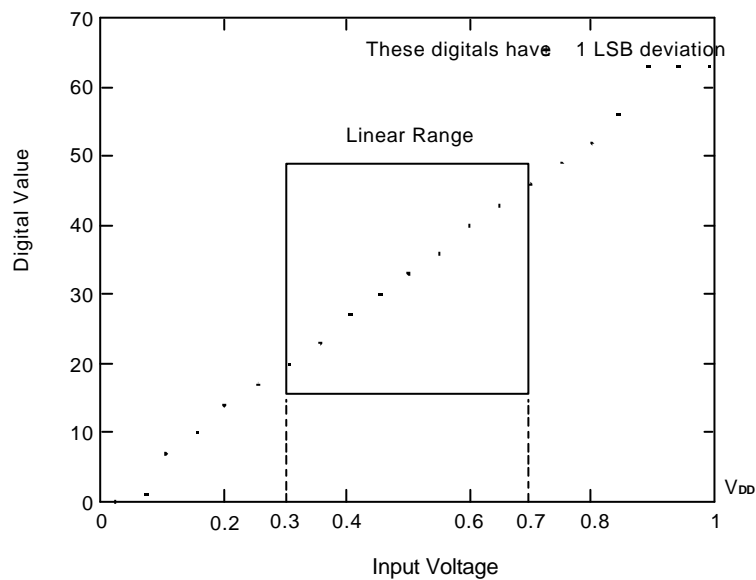
Figure 3. A/D Converter Linearity Diagram

7. PWM DACs (Pulse Width Modulation D/A Converters)

There are 14 PWM D/A converters with 8-bit resolution in NT6861. Eight of these D/A (DAC0 - DAC7) converters are open-drain output structures with 12V applied (maximum), and the other six D/A converters (DAC8 - DAC13) are open-drain output structures with 5V applied (maximum). The PWM frequency is 31.25 KHz on 8 MHz system clock. Use of a different oscillator frequency will result in different PWM frequency. As DAC8 - DAC13 are shared with I/O port pins, user can write '0' to corresponding enable bit in the ENDAC control register to activate each of DACH8 - 13. There are 14-channel readable DACH registers corresponding to 14 D/A converters. Each PWM output pulse width is programmable by setting the 8 bit digital to the corresponding DACH registers. When these DACH registers are set to 00H, the DAC will output LOW (GND level) and each bit addition will add 125ns pulse width. After reset, all DAC outputs are set to 80H (1/2 duty output). Refer to Figure 4 for the detailed timing diagram of PWM D/A output.

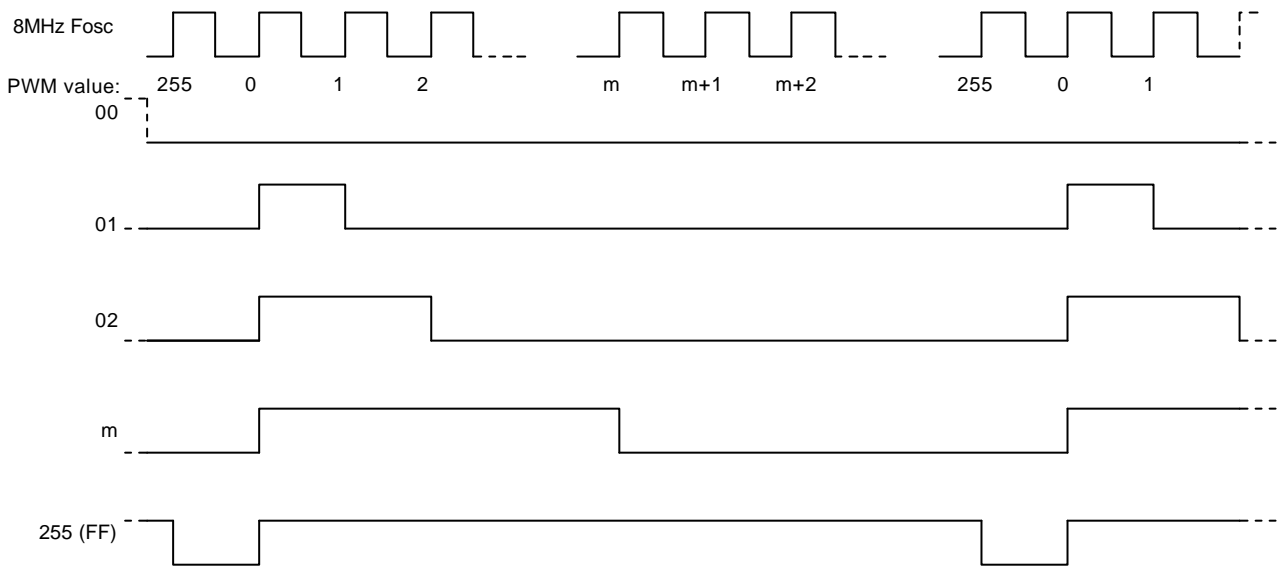

Figure 4. The DAC Output Timing Diagram and Wave Table

DKVL7	DKVL6	DKVL5	DKVL4	DKVL3	DKVL2	DKVL1	DKVL0	DAC Output Duty Cycle
0	0	0	0	0	0	0	0	GND
0	0	0	0	0	0	0	1	1/256 Vref.
0	0	0	0	0	0	1	0	2/256 Vref.
0	0	0	0	0	0	1	1	3/256 Vref.
0	0	0	0	0	1	0	0	4/256 Vref.
-	-	-	-	-	-	-	-	X /256 Vref.
1	1	1	1	1	1	1	0	254/256 Vref.
1	1	1	1	1	1	1	1	255/256 Vref.

The DAC value correspondent to PWM Output

* Vref. is 12V or 5V

Addr.	Register	INIT	Bit7	Bit6	Bit5	Bit4	Bit3	Bit2	Bit1	Bit0	
\$000C	ENDAC	FFH	$\overline{\text{ENAD1}}$	$\overline{\text{ENAD0}}$	$\overline{\text{ENDK13}}$	$\overline{\text{ENDK12}}$	$\overline{\text{ENDK11}}$	$\overline{\text{ENDK10}}$	$\overline{\text{ENDK9}}$	$\overline{\text{ENDK8}}$	W
\$0018	DACH0	80H	DKVL7	DKVL6	DKVL5	DKVL4	DKVL3	DKVL2	DKVL1	DKVL0	RW
\$0019	DACH1	80H	DKVL7	DKVL6	DKVL5	DKVL4	DKVL3	DKVL2	DKVL1	DKVL0	RW
\$001A	DACH2	80H	DKVL7	DKVL6	DKVL5	DKVL4	DKVL3	DKVL2	DKVL1	DKVL0	RW
\$001B	DACH3	80H	DKVL7	DKVL6	DKVL5	DKVL4	DKVL3	DKVL2	DKVL1	DKVL0	RW
\$001C	DACH4	80H	DKVL7	DKVL6	DKVL5	DKVL4	DKVL3	DKVL2	DKVL1	DKVL0	RW
\$001D	DACH5	80H	DKVL7	DKVL6	DKVL5	DKVL4	DKVL3	DKVL2	DKVL1	DKVL0	RW
\$001E	DACH6	80H	DKVL7	DKVL6	DKVL5	DKVL4	DKVL3	DKVL2	DKVL1	DKVL0	RW
\$001F	DACH7	80H	DKVL7	DKVL6	DKVL5	DKVL4	DKVL3	DKVL2	DKVL1	DKVL0	RW
\$0020	DACH8	80H	DKVL7	DKVL6	DKVL5	DKVL4	DKVL3	DKVL2	DKVL1	DKVL0	RW
\$0021	DACH9	80H	DKVL7	DKVL6	DKVL5	DKVL4	DKVL3	DKVL2	DKVL1	DKVL0	RW
\$0022	DACH10	80H	DKVL7	DKVL6	DKVL5	DKVL4	DKVL3	DKVL2	DKVL1	DKVL0	RW
\$0023	DACH11	80H	DKVL7	DKVL6	DKVL5	DKVL4	DKVL3	DKVL2	DKVL1	DKVL0	RW
\$0024	DACH12	80H	DKVL7	DKVL6	DKVL5	DKVL4	DKVL3	DKVL2	DKVL1	DKVL0	RW
\$0025	DACH13	80H	DKVL7	DKVL6	DKVL5	DKVL4	DKVL3	DKVL2	DKVL1	DKVL0	RW

DAC control register (\$000C) and DAC value register (\$0018 - \$0025)

Control Bit Description:

Addr.	Register	INIT	Bit7	Bit6	Bit5	Bit4	Bit3	Bit2	Bit1	Bit0	
\$000C	ENDAC	FFH	$\overline{\text{ENAD1}}$	$\overline{\text{ENAD0}}$	$\overline{\text{ENDK13}}$	$\overline{\text{ENDK12}}$	$\overline{\text{ENDK11}}$	$\overline{\text{ENDK10}}$	$\overline{\text{ENDK9}}$	$\overline{\text{ENDK8}}$	W
\$0018	DACH0	80H	DKVL7	DKVL6	DKVL5	DKVL4	DKVL3	DKVL2	DKVL1	DKVL0	RW

$\overline{\text{ENDK8}}$: Enable DAC channel 8; When clearing this bit to '0', the I/O port, P00, will change to DAC channel 8. When setting this bit to '1', the I/O port will restore to P00.

$\overline{\text{ENDK9}}$ - $\overline{\text{ENDK13}}$: The manipulation is the same as $\overline{\text{ENDK8}}$ bit, and control DAC channel 9 - 13.

DACH0 (DKVL0 - DKVL7): Setting DAC output waveform of DAC channel 8. Please check Figure 3 for the timing diagram and wave table.

DACH1 - DACH13: The manipulation is the same as DACH0 register, and control DAC channel 1 - 13.

8. RESET

NT6861 can be reset by the external reset pin or by the internal watch-dog timer. This resets or starts the microcontroller from a power-down condition. During the time that this reset pin is held low (*reset line must be held low for at least two CPU clock cycles), writing to or from the μ C is inhibited. When positive edge is detected on the reset input, the μ C will immediately begin reset sequence. After a system initialization time of six CPU clock cycles, the mask interrupt flag will be set and the μ C will load the program counter from the memory vector locations \$FFFC and \$FFFD. This is the start location for program control. To improve noise immunity a Schmitt Trigger buffer is provided at the $\overline{\text{RESET}}$.

Reset status is as follows:

1. PORT0 PORT1. PORT2. PORT3 pins will act as I/O ports with HIGH output.
2. Sync processor counters reset and VCNT | HCNT latches cleared
3. All sync outputs are disabled
4. Base timer is disabled and cleared

5. A/D Converter is disabled and stopped
6. DDC1/2B function is disabled
7. PWM DAC0 - DAC7 output 50% duty

```
as;   LDA   #$55
      STA   $0012
```

Addr.	Register	INIT	Bit7	Bit6	Bit5	Bit4	Bit3	Bit2	Bit1	Bit0	
\$0012	CLR WDT	-	0	1	0	1	0	1	0	1	W

- waveform and DAC8 - DAC13 is disabled
 8. Watch-dog timer is cleared and enabled

This $\overline{\text{RESET}}$ pin must be pulled high by external pulled-up resistor (5K Ω suggestion), or it will stay low voltage to reset system all the time (Refer to Figure 5).

9. Watch-dog timer (WDT)

NT6861 implements a watch-dog timer reset to avoid system shut-down or malfunction. The clock of the WDT is from on-chip RC oscillator not requiring any external components. The WDT runs regardless if the clock of the OSCI/OSCO pins of the device has been stopped. The WDT time interval is about 0.5 second. The WDT must be cleared within every 0.5 second when software is in normal sequence, otherwise the WDT will overflow and cause reset. The WDT is cleared and enabled after system is reset. It cannot be disabled by software. Users can clear the WDT by writing 55H to CLRWDT register.

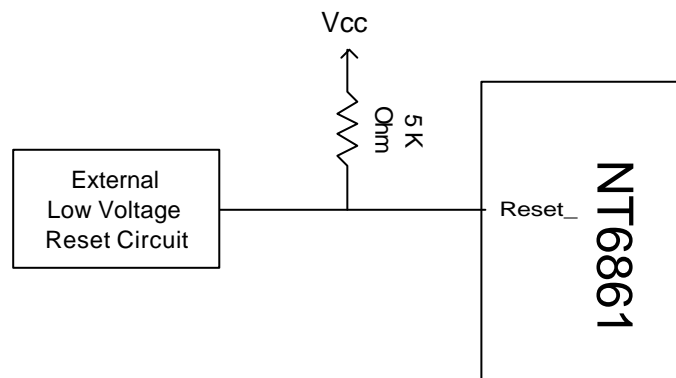

Figure 5. External Reset Suggested Circuit

10. Interrupt Controller

The μ C will complete the current instruction being executed before recognizing the interrupt request. At this time, the interrupt mask bit in the status register will be examined. If the interrupt mask bit is not set, μ C will begin interrupt sequence. The program counter and processor status register are stored in the stack. μ C will then set the interrupt mask flag HIGH so that no further interrupts occur. At the end of this cycle, the program counter will be loaded from addresses \$FFFE & \$FFFF, transferring program control to the memory vector located at these addresses.

Six interrupt sources are available in this system:

- INTV INT (Vsync INT): Rising edge of every Vsync pulse
- INTE INT (External INT): Rising edge of external interrupt pulse
- INTMR INT (Timer INT): As the Base Timer counter overflow and counting from \$FF to \$00
- INTA INT (Address Matched INT): External device calling NT6861 in DDC2 mode communication
- INTD INT (Shift Register INT): Shift register is empty or receiving a new byte data in DDC1 & DDC2 mode communication
- INTS INT (SCL Go-Low INT): External device proceed a DDC2 communication

Three memory mapped registers are used to control the interrupt operation. The IRQX is set by the rising edge of external pins (INTV & INTE), base timer overflow (INTR), SCL line go-low (INTS), and serial bus interrupt (INTA & INTD). The serial bus interrupt is generated by the μ C circuit as described in under μ C bus interface sections. The interrupt enable (IEX) bit will effects the interrupt process if the IRQX has already been set. Once IEX bit is set, its corresponding interrupt will generate an interrupt source for 6502 CPU. The IRQX will be set no matter the IEX bit enable or not. The interrupt request is generated when IRQX and IEX are both '1'. The IRQX remains in HIGH state unless the CLRIRQ register is cleared (write '1' to correspondent bit in CLRIRQ register). The interrupt enable register (IEX) and interrupt request register (IRQX) are memory mapped registers which can only be accessed or tested by program. These registers are cleared to '0' at initialization after the chip is reset .

When interrupt occurs, CPU jumps to \$FFFE & \$FFFF to execute interrupt service routine and finds which one of the interrupt sources is active by checking the IRQX. Upon entering the interrupt service routine, the IRQX that caused the interrupt service must be cleared in the interrupt service routine program. CPU clears IRQX by writing '1' to the corresponding bit in CLRIRQ register. If more than one interrupt is pending and waiting to be served, each is executed by priority. Priority is defined by the programmer.

Control bit description:

ADDR.	REGISTER	INIT	Bit7	Bit6	Bit5	Bit4	Bit3	Bit2	Bit1	Bit0	
\$000F	IEX	00H	-	-	IEINTS	IEINTD	IEINTA	IEINTR	IEINTE	IEINTV	W
\$0010	IRQX	00H	-	-	IRQINTS	IRQINTD	IRQINTA	IRQINTR	IRQINTE	IRQINTV	R
\$0011	CLR FLG	00H	CLRHOV	CLRVOV	CLRINTS	CLRINTD	CLRINTA	CLRINTR	CLRINTE	CLRINTV	W

IRQINTS is the interrupt flag for SCL- At DDC2B TRANSMISSION mode, it is set when SCL line changes from '1' to '0'.

IEINTS enable 6502 interrupt for INTS. - When this bit is set to '1' and IRQINTS flag is set, 6502 will accept interrupt source and jump to interrupt service routine assigned by interrupt vector.

CLRINTS clears INTS interrupt flag. - Before returning from interrupt service routine, this flag must be cleared.

The manipulation of other interrupt source is the same as INTS.

CLRHOV & CLRVOV: Clear the overflow flag of H/V counter and reset H/V counter to zero.

11. I/O PORTS

NT6861 has 25 pins dedicated to input and output. These pins are grouped into 4 ports .

11.1. Port0: P00 - P07

Port0 is an 8-bit bi-directional CMOS I/O port with PMOS as internal pull-up (Figure 6). Each pin of Port0 may be bit programmed as an input or output port without the software controlling the data direction register. When Port0 works as output, the data to be output is latched to the port data register and output to the pin. Port0 pins that have '1's written to them are pulled high by the internal PMOS pull-

ups. In this state they can be used as input, then the input signal can be read. This port outputs high after reset .

P00 - P05 are shared with DAC8 - DAC13 respectively. If user sets $\overline{\text{ENDK8}}$ - $\overline{\text{ENDK13}}$ LOW in ENDAC register, P00 - P05 will act as DAC8 - DAC13 respectively (Figure 7). After the chip is reset, $\overline{\text{ENDK}}$ - $\overline{\text{ENDK13}}$ will enter HIGH state and P00 - P05s will act as I/O ports.

P06, P07 are shared with VSYNCO & HSYNCO respectively. If user sets $\overline{\text{ENH}}$, $\overline{\text{ENV}}$ to low in SYNCON register, P06, P07 will act as VSYNCO & HSYNCO respectively (Figure 8). After the chip is reset, $\overline{\text{ENH}}$, $\overline{\text{ENV}}$, will enter high state and P06, BP07 will act as I/O pins.

Addr.	Register	INIT	Bit7	Bit6	Bit5	Bit4	Bit3	Bit2	Bit1	Bit0	
\$0000	PT0	FFH	P07	P06	P05	P04	P03	P02	P01	P00	RW
\$000B	SYNCON	FFH	$\overline{\text{NOHALF}}$	$\overline{\text{ENHALF}}$	-	$\overline{\text{FRUN}}$	$\overline{\text{FRFREQ}}$	HALFPO L	$\overline{\text{ENH}}$	$\overline{\text{ENV}}$	W
\$000C	ENDAC	FFH	ENAD1	ENAD0	$\overline{\text{ENDK13}}$	$\overline{\text{ENDK12}}$	$\overline{\text{ENDK11}}$	$\overline{\text{ENDK10}}$	$\overline{\text{ENDK9}}$	$\overline{\text{ENDK8}}$	W

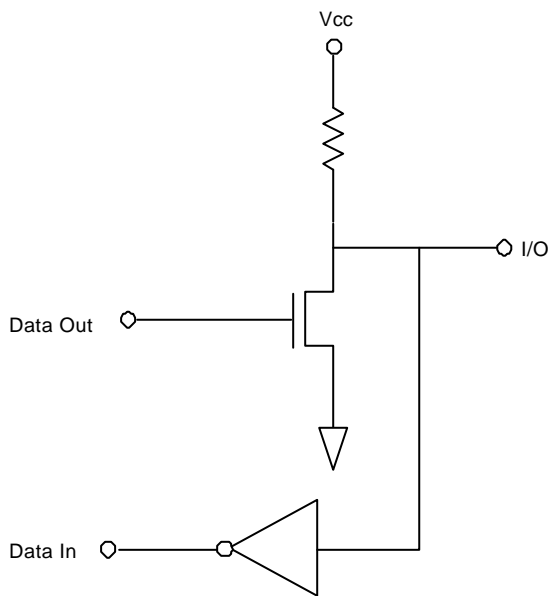

Figure 6. I/O Structure

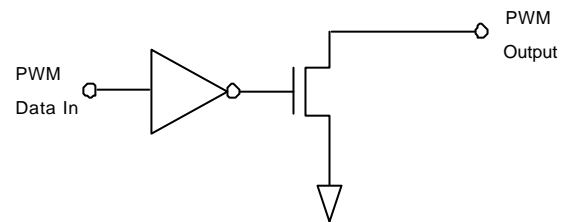

Figure 7. PWM Output Structure

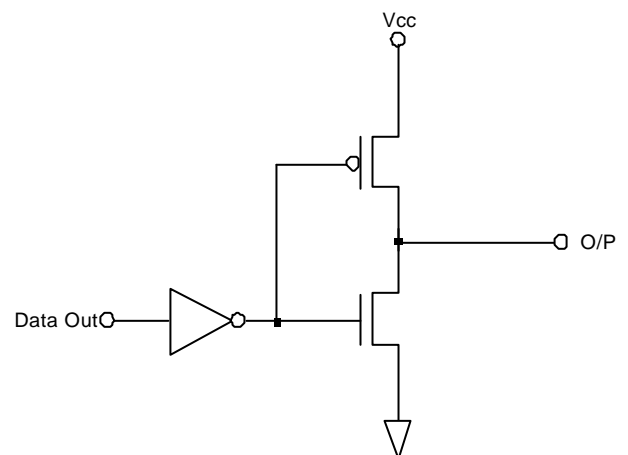

Figure 8. Output Structure

11.2. Port1: P10 - P16

Port10-Port15 are 6-bit bi-directional CMOS I/O ports with PMOS as the internal pull-up (Figure 6). Port16 is an input pin only. Each bi-directional I/O pin may be bit programmed as an input or output port without software controlling the data direction register. When Port1 works as output, the data to be output is latched to the port data register and output to the pin. Port1 pins that have '1's written to them are pulled high after reset.

P10, P11 are shared with AD0 & AD1 input pins respectively. If user clears the $\overline{\text{ENADX}}$ bit in the ENDAC control register to low, A/D converters will activate simultaneously. After the chip is reset, $\overline{\text{ENADX}}$ bits enter HIGH state and P10, P11 act as I/O pins.

P12, P13 are shared with half signals input and output pins by accessing SYNCON control register. If user clears the $\overline{\text{ENHALF}}$ bit to low, P13 will switch to HALFHI pin (input pin) and P12 will switch to HALFHO pin (output pin, Figure 8). Refer to half frequency function in the H/V sync processor paragraph concerning HALFHI & HALFHO pin. After the chip is reset, the $\overline{\text{ENHALF}}$ bits will enter HIGH state and P12, P13 will act as I/O pins.

P16 has a Schmitt Trigger input buffer (Figure 9) and is shared with the external interrupt pin if set the IEINTE bit in IEX control register. Refer to 'Interrupt Controller' section above for function details.

Addr.	Register	INIT	Bit7	Bit6	Bit5	Bit4	Bit3	Bit2	Bit1	Bit0	
\$0001	PT1	7FH	-	P16	P15	P14	P13	P12	P11	P10	RW
\$000C	ENDAC	FFH	$\overline{\text{ENAD1}}$	$\overline{\text{ENAD0}}$	$\overline{\text{ENDK13}}$	$\overline{\text{ENDK12}}$	$\overline{\text{ENDK11}}$	$\overline{\text{ENDK10}}$	$\overline{\text{ENDK9}}$	$\overline{\text{ENDK8}}$	W
\$000D	AD0 REG	C0H	$\overline{\text{CEND}}$	$\overline{\text{CSTA}}$	AD05	AD04	AD03	AD02	AD01	AD00	R W
\$000E	AD1 REG	00H	-	-	AD15	AD14	AD13	AD12	AD11	AD10	R
\$000F	IEX	00H	-	-	IEINTS	IEINTD	IEINTA	IEINTR	IEINTE	IEINTV	W

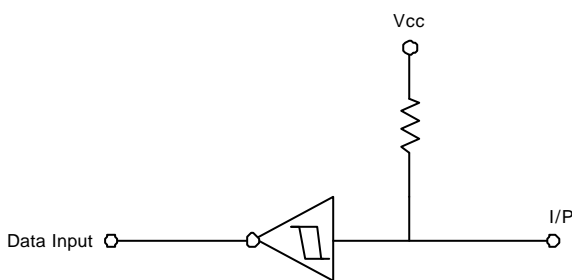
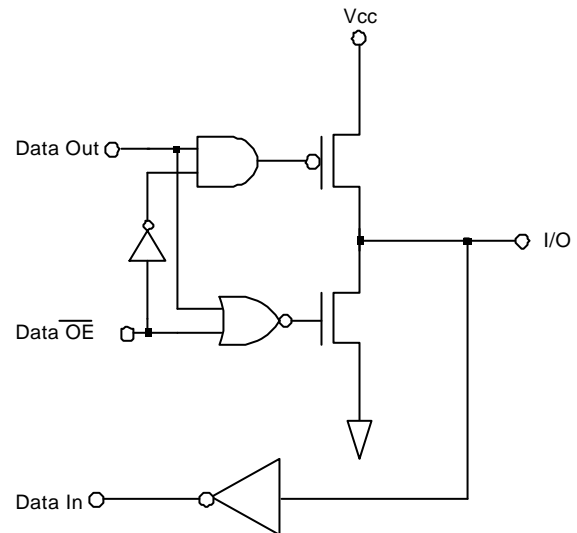
Figure 9. Schmitt Input Structure

Figure 10. I/O Structure

11.3. Port2: P20 - P27

Port2, an 8-bit bi-directional I/O port (Figure 10), which may be programmed as an input or output pin by the software control. When setting the PT2DIR control bit to '0', its corresponding pin will act as output pin. Clearing PT2DIR bit to '1', acts as an input pin. When programmed as an input, it has an internal pull-up resistor. When programmed as an output, the data to be output is latched to the port data register and output to the pin with push-pull structure. If programmed as an output pin, user can read out its correspondent control bit about what user has written before. If programmed as an input pin, user can read out what the I/O pin status outside. This port acts as an input port after reset.

Addr.	Register	INIT	Bit7	Bit6	Bit5	Bit4	Bit3	Bit2	Bit1	Bit0	
\$0002	PT2DIR	FFH	$\overline{P27OE}$	$\overline{P26OE}$	$\overline{P25OE}$	$\overline{P24OE}$	$\overline{P23OE}$	$\overline{P22OE}$	$\overline{P21OE}$	$\overline{P20OE}$	W
\$0003	PT2	FFH	P27	P26	P25	P24	P23	P22	P21	P20	RW

11.4. Port3: P30 - P31

Port3 is an 2 bit bi-directional open-drain I/O port (Figure 11). Each pin of Port3 may be bit programmed as an input or output pin with open drain structure. When Port3 works as an output, the data to be output is latched to the port data register and output to the pin. For Port3 pins that have '1's written to them, user must connect PORT3 with external pulled-up resistor and then PORT3 can be used as input (the input signal can be read). This port outputs high after reset.

P30, BP3 include Schmitt Trigger buffer for noise immunity and can be configured as the I²C pins SDA & SCL respectively. If set \overline{ENDDC} to LOW in IISTS control register, P30, P31 will act as SDA, SCL respectively. After the chip is reset, \overline{ENDDC} will be in HIGH and PORT3 will act as I/O pins.

Addr.	Register	INIT	Bit7	Bit6	Bit5	Bit4	Bit3	Bit2	Bit1	Bit0	
\$0004	PT3	03H	-	-	-	-	-	-	P31	P30	RW
\$0015	IISTS	0FH	-	-	START START	STOP STOP	\overline{ENDDC}	TRX	RXAK		R W

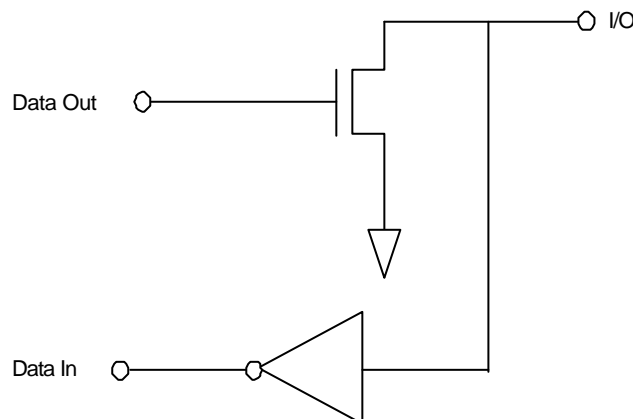
Figure 11. Open Drain I/O Structure

12. H/V sync signals processor

The functions of the sync processor include polarity detection, Hsync & Vsync signals counting, programmable sync signals output, free running signal generator and composite sync separation. The processor properly handles either composite or separate sync signal inputs as well as no sync signal input. The input at HSYNCI can be either a pure horizontal sync signal or a composite sync signal. For the sync waveform refer to Figures 12 and 13. The sync processor block diagram is shown in Figure 17. Both VSYNCI & HSYNCI pins have a Schmitt Trigger and filtering process to improve noise immunity. Any pulse that is shorter than 125ns will be regarded as a glitch and will be ignored.

12.1. V & H Counter Register: VCNTL/H, HCNTL/H

Vsync counter: VCNTL/H, the 12-bit read only register, contains information of the Vsync frequency. An internal counter counts the numbers of 8 μ s pulse between two Vsync pulses. When the next Vsync signal is recognized, the counter is stopped and the VCNT register latches the counter value. The counted data can be converted to the time duration between two successive Vsync pulses by 8 μ s. If no Vsync comes, the counter will overflow and set

VCNTOV bit (in HVCON register) to HIGH (see Figure 14). Once the VCNTOV sets to HIGH, it keeps in HIGH state unless cleared by CLRVOV bit (in CLRFLG register) to HIGH. When user clears the CLRVOV bit, the VCNT counter will be reset to zero and begin to count again.

Hsync counter: HCNTL/H, the other 12-bit read only register pairs contain the numbers of Hsync pulse between two Vsync pulses (see Figure 15), and the data can be read to determine if the frequency is valid and to determine the VIDEO mode. If the $\overline{\text{HSEL}}$ bit sets to HIGH, the internal counter counts the Hsync pulses between two Vsync pulses. If the $\overline{\text{HSEL}}$ bit clears to LOW, the internal counter will be reset and begin counting the Hsync pulses in each 8.192ms interval (see Figure 16). The counted value will be latched by the HCNTL/H register pairs which are updated by every Vsync pulse or 8.192ms interval. If the counter overflows, the HCNTOV bit (in HVCON register) will be set to HIGH. Once the HCNTOV sets to HIGH, it remains in the overflow HIGH state unless cleared by CLRHOV (in CLRFLG register) to HIGH. When user clears the CLRHOV bit, the HCNT counter will be reset to zero.

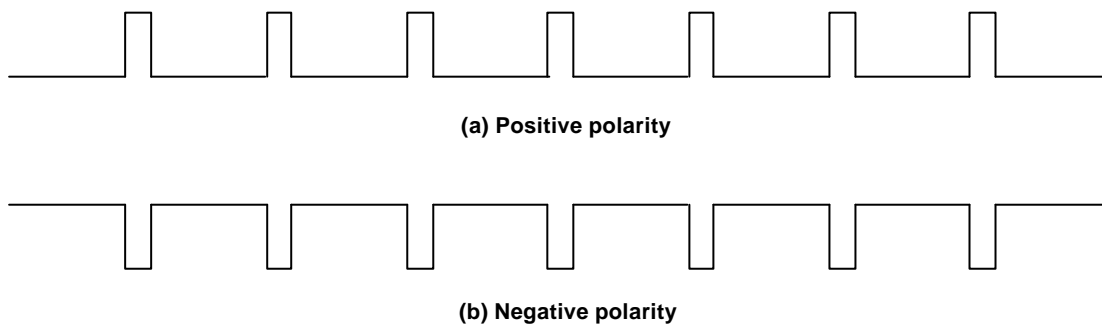

Figure 12. Separate H Sync. Waveform

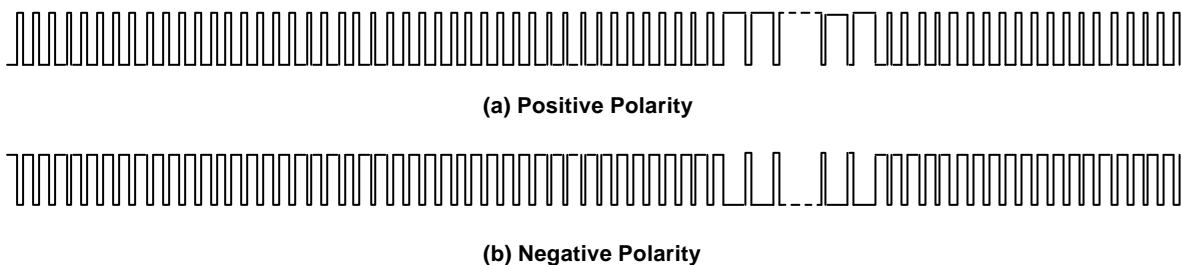
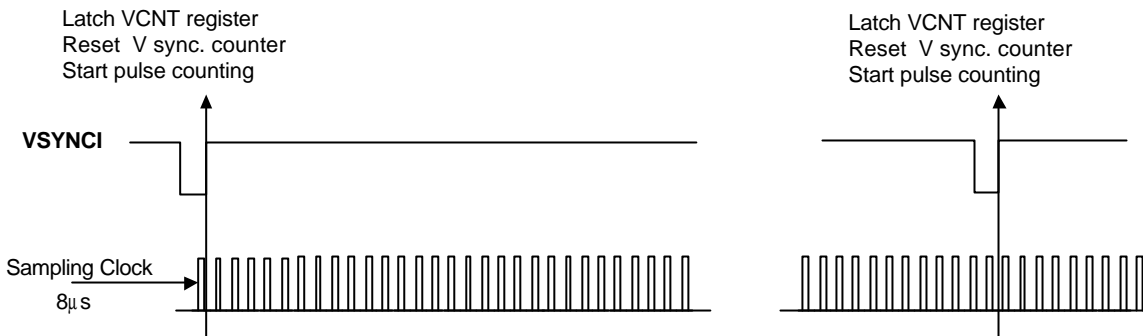
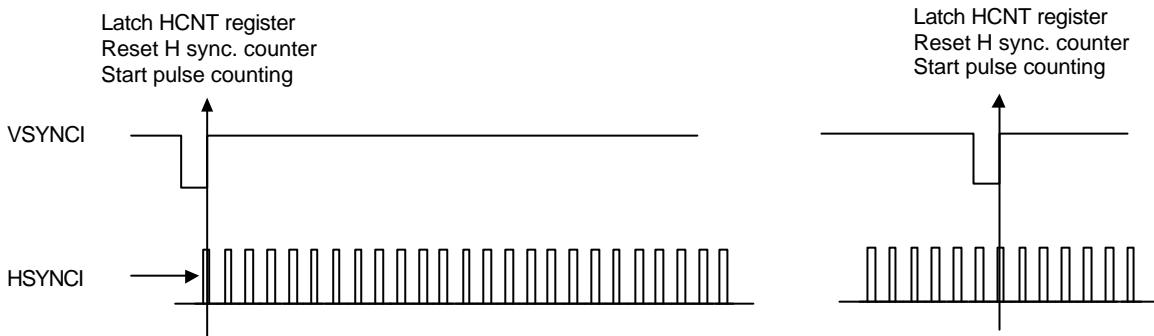
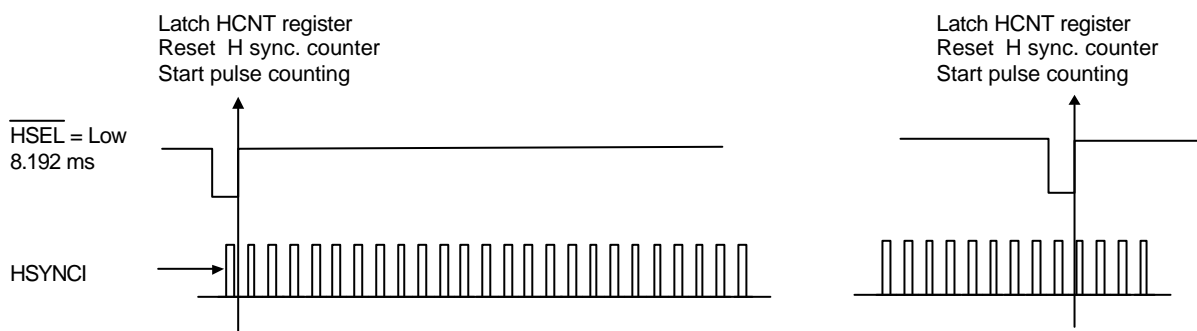

Figure 13. Composite H Sync. Waveform

Figure 14. Vsync counter Operation

Figure 15. Hsync Counter Operation Using Vsync Pulse

Figure 16. Hsync Counter Operation Using 8.192ms Time Interval

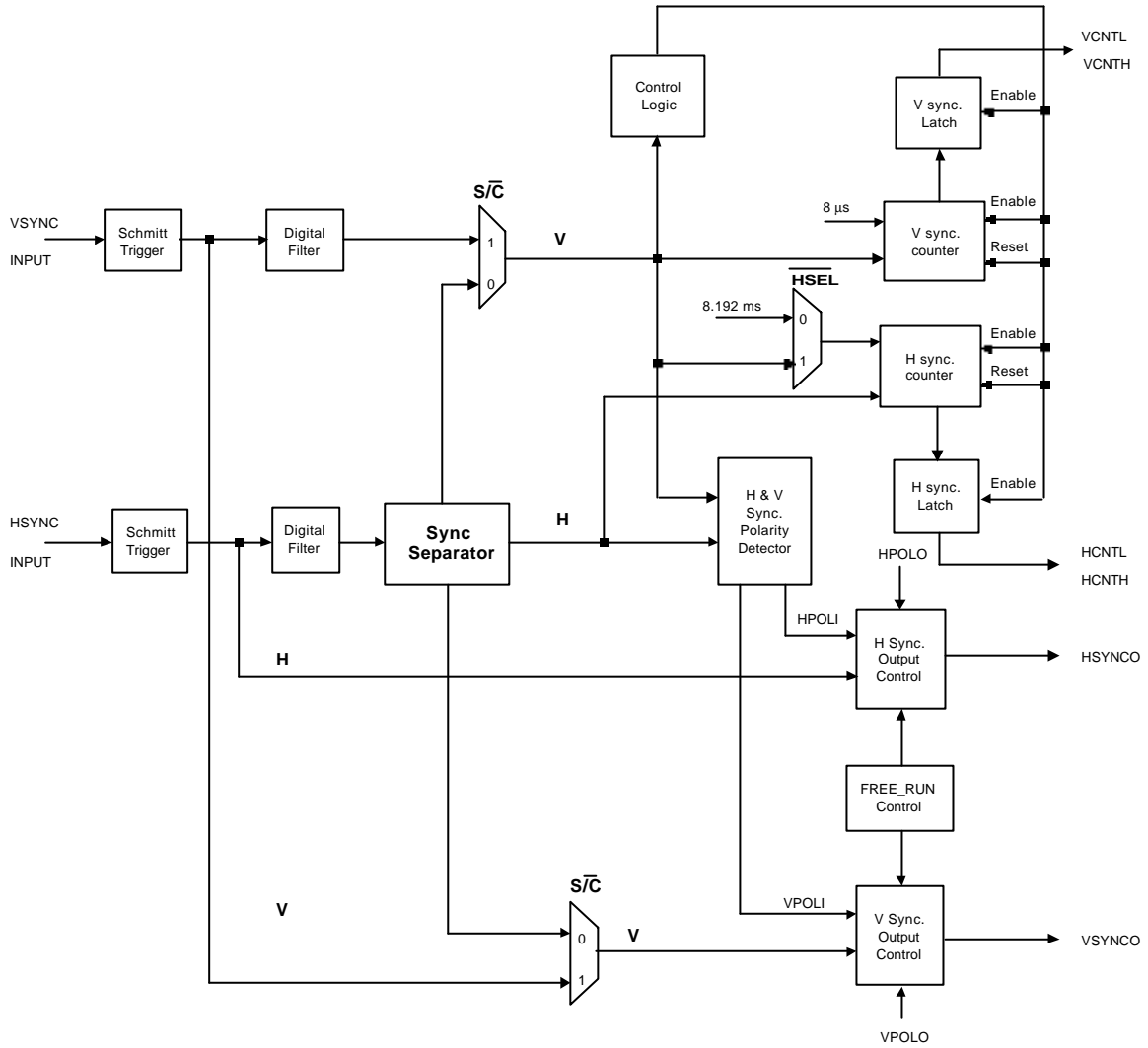

Figure 17. Sync. Processor Block Diagram

12.2. Sync Processor Control Register:

Composite sync: User has to determine whether the incoming signal is separate sync or composite sync and set S/\bar{C} & \overline{HSEL} bit properly. If composite sync signal is input, after set S/\bar{C} to '0', the sync separator block will be activated (please refer figure 18). During Vsync pulse the Hsync will be inserted Hsync pulse by hardware circuit and the pulse width of inserted pulse is 2 μ s fixed. According to the last Hsync pulse outside the Vsync pulse duration, the hardware will arrange the interval of these hardware interpolated pulse. So the insertion of these Hsync pulse will be continued inside the Vsync pulse duration no matter what the Hsync pulse originally exist or not. These inserted Hsync pulse have 0.5 μ s phase deviation maximum. The Vsync pulse can be extracted by hardware from composite signal, and the output of Vsync signal delay time will be limited bellow 20ns. For inserting Hsync pulse safely, the extracted Vsync pulse will be widen about 9 μ s. Because evenly putting the Hsync pulse, the last inserted Hsync pulse will have different frequency from original ones.

System will not implement this insertion function, user must clear \overline{INSEN} bit in the MD_CON control register to activate this function.

After reset, the \overline{HSEL} , S/\bar{C} & \overline{INSEN} bits default value is HIGH and clear the VCNT | HCNT counter latches to zero.

Polarity: The detection of Hsync or Vsync polarity is achieved by hardware circuits sample the sync signal's voltage level periodically. The user can read HPOLI & VPOLI bit in HVCON register, from which bit = '1' representing positive polarity and '0', negative polarity. The user can read HSYNCl and VSYNCl bit in HVCON register to detect H & V sync input signal. The user can control the polarity of H & V sync output signal by writing the appropriate data to the HPOLO and VPOLO bits in the HVCON register, '1' represents positive polarity and '0', negative polarity.

Sync output: In pin assignment, VSYNCO & HSYNCO represent Vsync & Hsync output which are shared with P06 & P07 respectively. If set \overline{ENV} & \overline{ENH} to '0' in SYNCON register, P06 & P07 will act as VSYNCO & HSYNCO pin. When input sync is separate signal, the V/HSYNCO will output the same signal as input sync signal without delay. But if input sync is composite signal, the VSYNCO signal will have a delay time of about 4 μ s to 8 μ s. The HSYNCO has no delay output and still has Vsync pulse among Hsync pulse (i.e. the signal on HSYNCl pin directly output to HSYNCO pin.)

Free run signal output: The user can set \overline{FRUN} to '0' bit in SYNCON register, then VSYNCO will output 61Hz Vsync signal and HSYNCO will output 62.5KHz Hsync signal default (Refer to Figure 20). When \overline{FRFREQ} bit clears to '0', the HSYNCO pin will output 41.7 KHz Hsync signal. The free run signal has negative or positive polarity depending on the HPOLO & VPOLO bit setting in the HV_CON control register, '1' is positive and '0' is negative polarity. After chip reset, \overline{ENV} , \overline{ENH} , \overline{FRFREQ} & \overline{FRUN} will enter HIGH state and P06 & P07 will act as I/O pins.

Half frequency input and output: In this pin assignment, when \overline{ENHALF} sets to '0' in SYNCON register, the HALFHO pin will act as an output pin and output half of input signal in the HALFHI pin with 50% duty (Refer to Figure 21). If \overline{NOHALF} sets to '0', HALFHO will output the same signal in the HALFHI pin and user can control its polarity output of HALFHO by setting HALFPOL bit, '1' for positive and '0' for negative polarity. After chip reset, \overline{ENHALF} , \overline{NOHALF} & HALFPOL will be in the HIGH state and P13 & P17 will act as I/O pins.

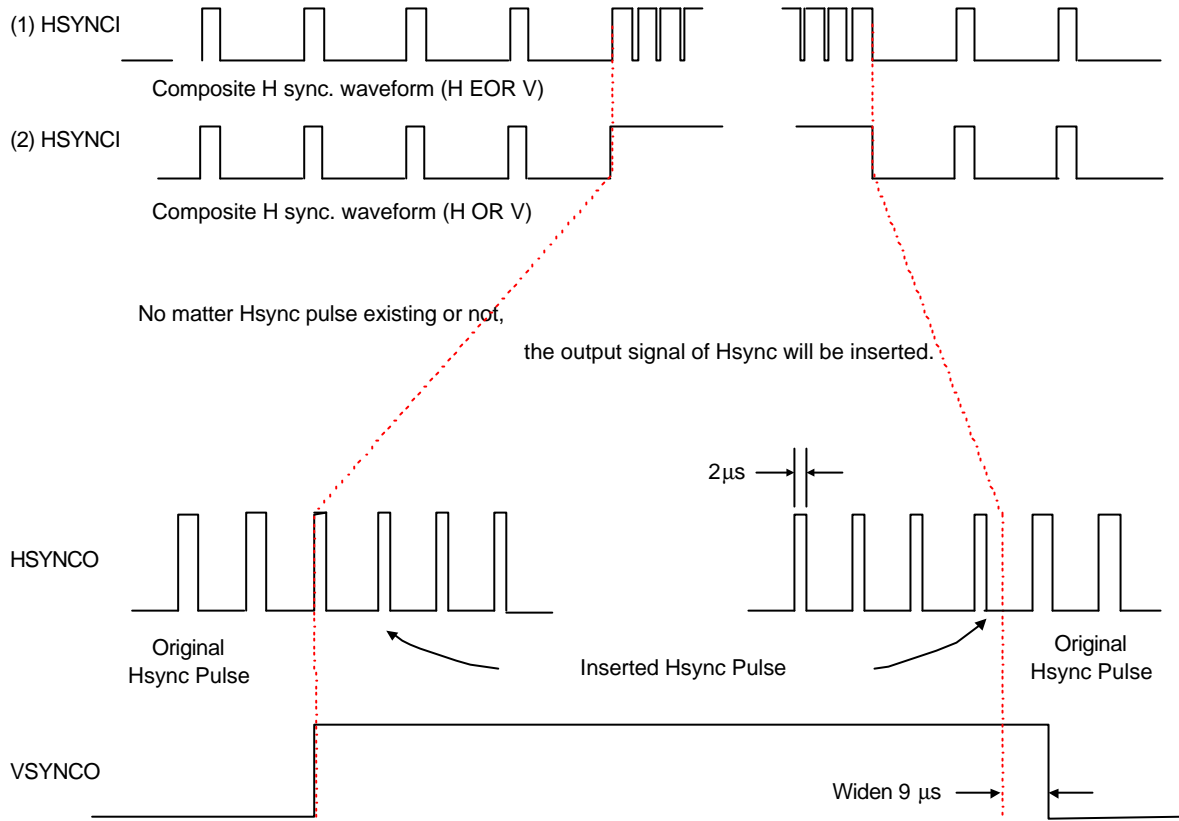

Figure 18. Composite H & V Sync. Processing

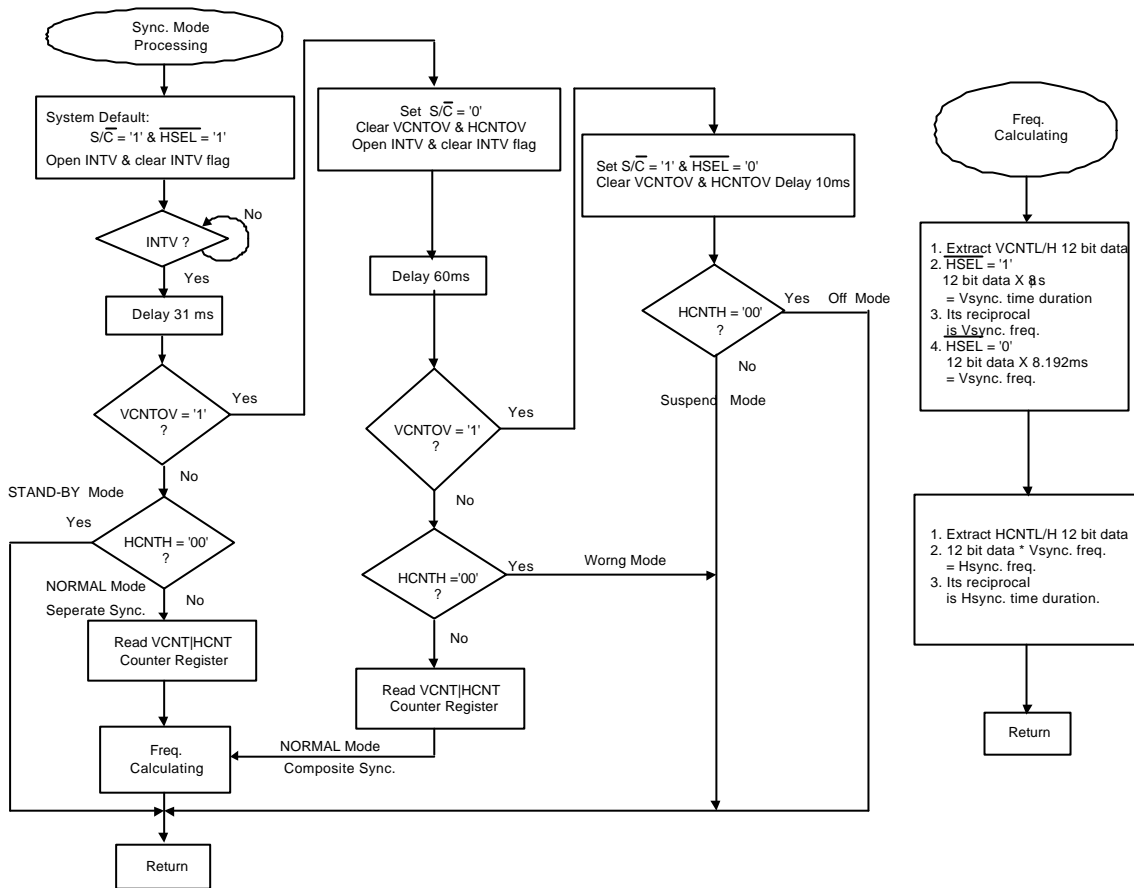

Figure 19. H & V Sync. Software Control Flowchart (for reference only)

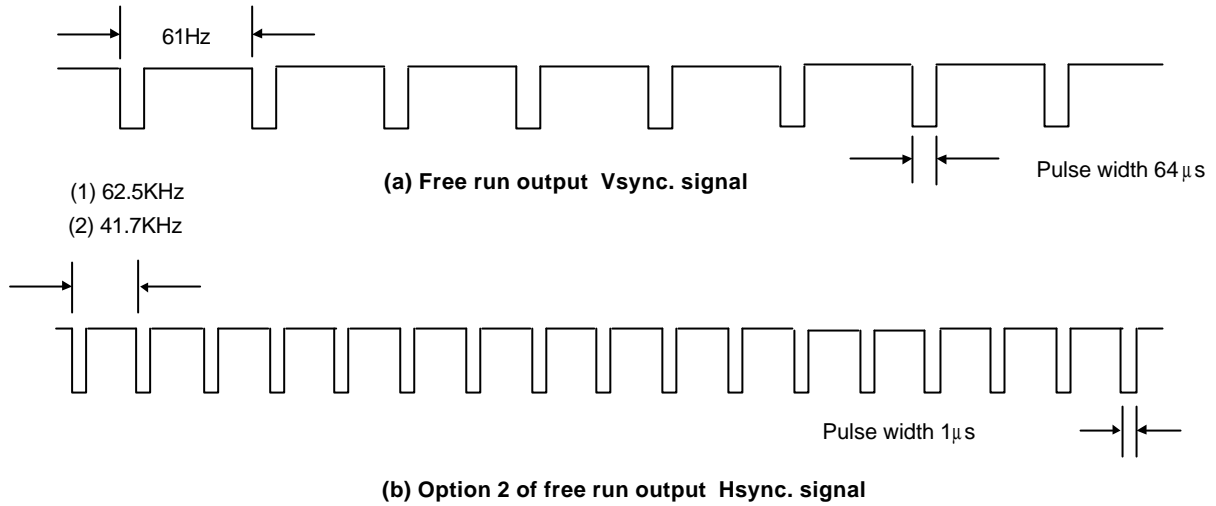

Figure 20. Free Running Sync. Waveform

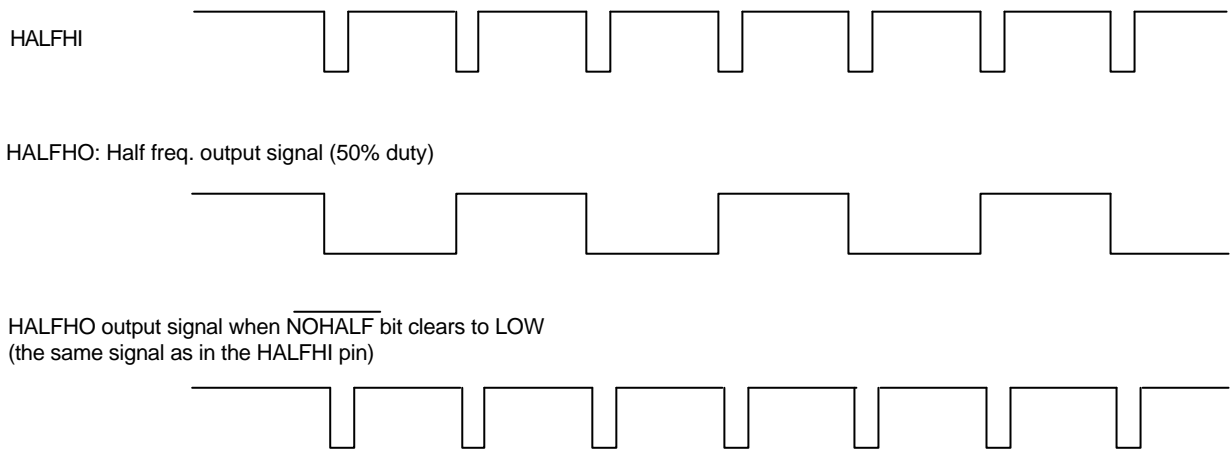

Figure 21. Half Freq. Sync. Waveform

12.3. Power Saving mode detect:

The VIDEO mode is listed below. Power saving is from mode 2 to mode 4. All modes can be detected by setting the control register properly. Refer to Figure 15 control flow chart for software reference.

Mode	H-Sync	V-Sync
(1) Normal	Active	Active
(2) Stand by	Inactive	Active
(3) Suspend	Active	Inactive
(4) Off	Inactive	Inactive

Control bit description:

Addr.	Register	INIT	Bit7	Bit6	Bit5	Bit4	Bit3	Bit2	Bit1	Bit0	
\$0005	MD CON	07H	- -	- -	- -	- -	- INSEN	- HSEL	S/C S/C	MD1/ $\bar{2}$ MD1/ $\bar{2}$	R W
\$0006	HV CON	2FH	HCNTOV	VCNTOV	HSYNCI	VSYNCI	HPOLI	VPOLI	HPOLO	VPOLO	R W
\$0007	HCNT L	00H	HCL7	HCL6	HCL5	HCL4	HCL3	HCL2	HCL1	HCL0	R
\$0008	HCNT H	00H	-	-	-	-	HCH3	HCH2	HCH1	HCH0	R
\$0009	VCNT L	00H	VCL7	VCL6	VCL5	VCL4	VCL3	VCL2	VCL1	VCL0	R
\$000A	VCNT H	00H	-	-	-	-	VCH3	VCH2	VCH1	VCH0	R
\$000B	SYNCON	FFH	$\overline{\text{NOHALF}}$	$\overline{\text{ENHALF}}$	-	$\overline{\text{FRUN}}$	$\overline{\text{FRFREQ}}$	HALFPOL	$\overline{\text{ENH}}$	$\overline{\text{ENV}}$	W
\$0011	CLR FLG	00H	CLRHOV	CLRVOV	CLRINTS	CLRINTD	CLRINTA	CLRINTR	CLRINTE	CLRINTV	W

MDCON control register:

S/\bar{C} : The SYNC MODE control. If the input of V & H Sync are separate signals, set this bit to '1' (system default). If the input is composite signal, clear this bit. Under the COMPOSITE mode, NT6861 will extract the V Sync form H Sync signal.

$\overline{\text{HSEL}}$: When clearing this bit, system will reset HCNTLH counter to zero. The number of Hsync pulse at the 8.192ms interval is obtained.

$\overline{\text{INSEN}}$: User can clear this bit for inserting Hsync pulse when processing the composite signal. System will disable this function after reset.

HVCON control register:

HCNTOV: The overflow bit of H Sync. After setting $\overline{\text{HSEL}}$ bit '1' without any input Vsync pulses and there are more than 4096 Hsync pulses coming, this bit will be set. It will keep '1' and user can clear it by setting CLRHOV bit to '1' at the CLRFLG control register. After cleared, the H Sync counter will reset to '0' and start counting for every Hsync pulse.

VCNTOV: The overflow bit of V Sync. The operation is the same as HCNTOV. After cleared, the Vsync counter will reset to '0' and start counting for every 8 μ s.

HSYNCI & VSYNCI: User can instantaneously detect input of H & V Sync pulse at any time.

HPOLI & VPOLI: The polarity of input H & V Sync pulse - '1' for positive polarity and '0' for negative polarity.

HPOLO & VPOLO: To control the output polarity of H & V Sync pulse - '1' for positive polarity and '0' for negative polarity.

HCNTLH & VCNTLH control registers:

The 12 bits counter for H & V Sync pulse.

SYNCON control register:

$\overline{\text{ENH}}$ & $\overline{\text{ENV}}$: Enable the output of H & V Sync. The P06 & P07 will switch to VSYNCO & HSYNCO output.

$\overline{\text{FRUN}}$: Open free run signal at the VSYNCO & HSYNCO output.

$\overline{\text{FRFREQ}}$: Select the free run frequency of H Sync output.

$\overline{\text{ENHALF}}$: P12 & P13 will switch to HALFHO & HALFHI pin. The HALFHO will output the half signal at the HALFHI pin with 50% duty.

$\overline{\text{NOHALF}}$: User must clear $\overline{\text{ENHALF}}$ first. The HALFHO will output the same signal at the HALFHI pin.

HALFPOL: User must clear $\overline{\text{ENHALF}}$ first and control the polarity at the HALFHO output pin - '1' for

positive polarity and '0' for negative polarity.

13. BASE TIMER (BT)

The Base Timer is an 8-bit counter whose clock source must be chosen with 1 μ s or 1ms by setting or clearing the TBS bit ('0' for 1 μ s and '1' for 1ms). The BT can be enabled/disabled by the $\overline{\text{ENBT}}$ bit in the BTCON register. When user clearing this control bit to '0', the BT will start counting, otherwise setting this bit to '1' will stop the counting. After chip is reset, the TBS and $\overline{\text{ENBT}}$ bits are set to '1' (the BT is disabled). BT, can be preset by writing BT7 - BT0 to the BT register (write only) at any time and the BT will start count-up from preset value. When the value reaches FFH, it generates a timer interrupt if the timer interrupt is enabled. When it reaches the maximum value of FFH, the base timer will wrap around and begin counting at 00H. The timer interval can be within 256 ms maximum if set TBS to '1'. The timer interval can be within 256 μ s maximum if set TBS to '0'.

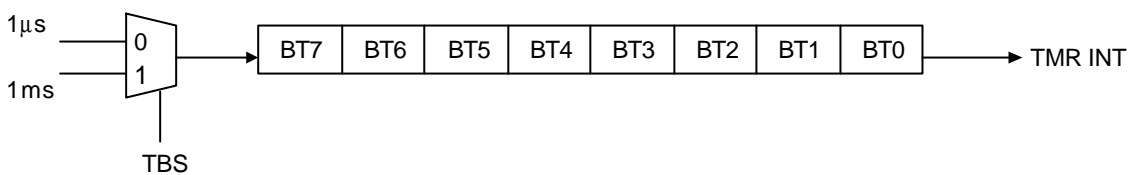

Control bit description:

Addr.	Register	INIT	Bit7	Bit6	Bit5	Bit4	Bit3	Bit2	Bit1	Bit0	
\$0016	BT	00H	BT7	BT6	BT5	BT4	BT3	BT2	BT1	BT0	W
\$0017	BT CON	03H	-	-	-	-	-	-	TBS	$\overline{\text{ENBT}}$	W

BT control register :

BT0 - BT7: Preloaded value of the base timer. The timer will count-up from this value.

BTCON control register:

$\overline{\text{ENBT}}$: When clearing this bit, the base timer will be activated.

TBS: Select the input clock source of base timer - '1' for 1ms and '0' for 1 μ s.

14. I²C bus interface: DDC1 & DDC2B Slave Mode

I²C bus interface is a two-wire, bi-directional serialbus which provides a simple, efficient way for data communication between devices. Its structure minimizes the cost of connecting various peripheral devices. In short, the wired-AND connection of all I²C interface to I²C bus is the most important structure. Two modes of operation have been implemented in NT6861: UNI-DIRECTIONAL mode (DDC1 mode) and BI-DIRECTIONAL mode (DDC2B mode). If the MD1/2̄ bit is set to '1', the device will operate in the DDC1 mode, and if the MD1/2̄ bit is cleared to '0', the device will operate in the DDC2B mode. All of these I²C functions will be activated only when ENDDC̄ bit clears to '0' (in IISTS register). When I²C bus function is activated, the P30 & P31 will switch to SCL & SDA pin. System works on the DDC1 mode transmission default. The SCL pin will remain high and SDA will transfer one bit of data at every rising edge of Vsync pulse.

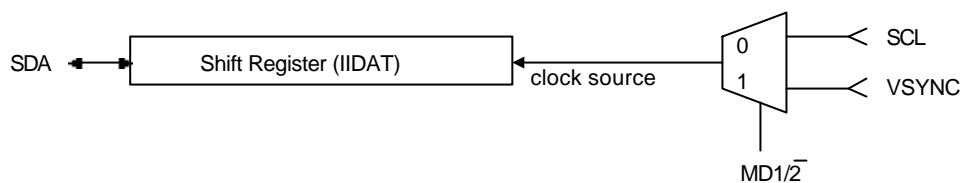

14.1. DDC1 bus interface

Vsync input and SDA pin: In DDC1 data transfer, the Vsync input pin is used as an input clock for data transmission and SDA output pin, as serial data line. This function comprises of two data buffers: one is a preloaded data buffer for user placing one bit of data in advance, and one is shift register for system shifting out one bit of data to the SDA pin. These two data buffer cooperate properly. Refer to Figure 18. After system reset, the I²C bus interface is in DDC1 mode.

Data transfer: In advance, put one byte transmitted data into IIDAT register and activate I²C bus by setting ENDDC̄ bit to '0' and open INTD interrupt source by setting IEINTD to '1'. On the first 9 rising edge of Vsync, system will shift out any invalid bit in shift register to SDA pin to empty shift register. When shift register is empty and on next rising edge of Vsync, it will load data in the IIDAT register to internal shift register. At the same time, NT6861 will shift

out MSB bit and generate an INTD interrupt to remind user to replace next byte data into IIDAT register. After eight rising clocks, there are eight bits shifted out in proper order and the shift register becomes empty again. At the ninth rising clock, it will shift the ninth bit (null bit '1') out to SDA. And on the next rising edge of Vsync clock, system will generate a INTD interrupt again. NT6861 will also load new data in the IIDAT register to internal shift register and shift out one bit immediately. User must input new data to IIDAT register properly before the shift register is empty (the next INTD interrupt).

Vsync clock: In the separate sync signal, the Vsync pulse is used as a data transfer clock. Its frequency allows 25KHz maximum. If no Vsync input signal is found, NT6861 can not transmit any data to SDA pin regardless what the Vsync has extracted from composite Hsync signal.

Control bit description:

Addr.	Register	INIT	Bit7	Bit6	Bit5	Bit4	Bit3	Bit2	Bit1	Bit0	
\$0005	MD CON	07H	- -	- -	- -	- -	- INSEN	- HSEL	S/ \bar{C} S/ \bar{C}	MD1/ $\bar{2}$ MD1/ $\bar{2}$	R W
\$000F	IEX	00H	-	-	IEINTS	IEINTD	IEINTA	IEINTR	IEINTE	IEINTV	W
\$0010	IRQX	00H	-	-	IRQINTS	IRQINTD	IRQINTA	IRQINTR	IRQINTE	IRQINTV	R
\$0011	CLR FLG	00H	CLRHOV	CLRVOV	CLRINTS	CLRINTD	CLRINTA	CLRINTR	CLRINTE	CLRINTV	W
\$0014	II DAT	00H	SR7	SR6	SR5	SR4	SR3	SR2	SR1	SR0	RW
\$0015	II STS	08H	-	-	START START	STOP STOP	$\overline{\text{ENDDC}}$	TRX	RXAK	- TXAK	R W

MDCON control register:

MD1/ $\bar{2}$: Select the DDC mode - '1' for DDC1 and '0' for DDC2B mode. System will be DDC1 mode by default.
When transmission mode is changed from DDC1 to DDC2B, system automatically clears this bit.

IEX control register:

At DDC1 mode, only open INTD interrupt, as well as open INTS interrupt to detect if has changed to DDC2B mode.

II_DAT control register: Data buffer for transmission.

II_STS control register:

$\overline{\text{ENDDC}}$: When clearing this bit, system will activate DDC transmission. P30 & P31 will switch to SDA & SCL pin.

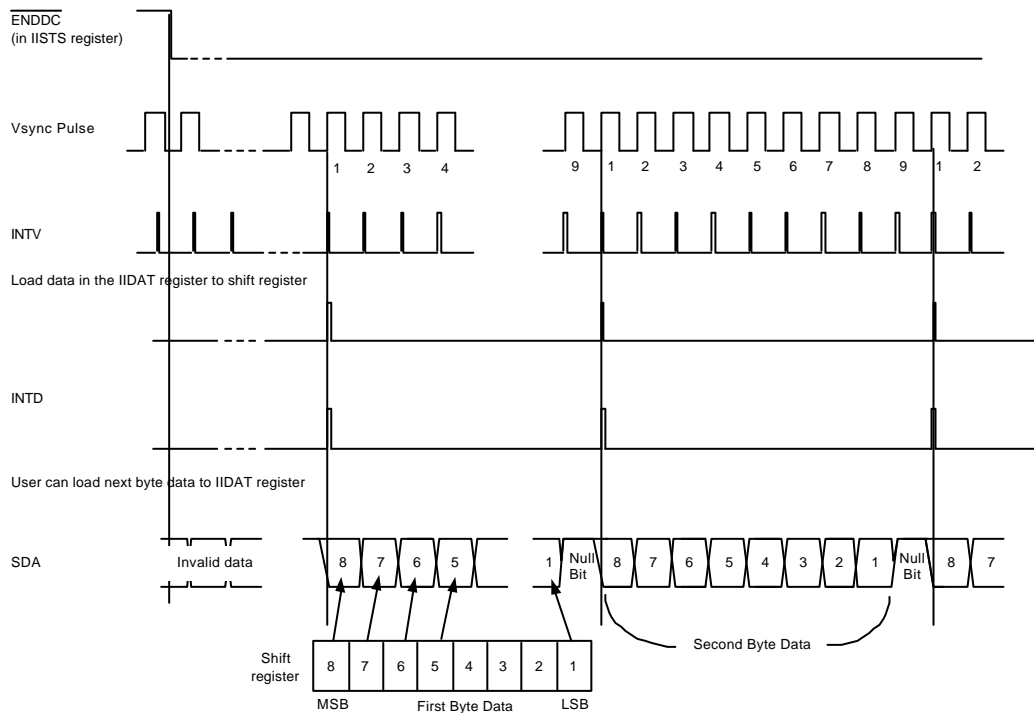

Figure 22. DDC1 Mode Timing Diagram

14.2 DDC2B Slave Mode bus interface

The DDC2B fC Bus Interface features are as follows:

- SLAVE mode (NT6861 addressed by a master which drive SCL signal)
- Fully compatible with I²C bus standard
- Interrupt and generation of acknowledge handled by user for communication
- Interrupt driven byte by byte data transfer
- Calling address identification interrupt
- Detection of START and STOP signals

Enable fC and INTS: The NT6861 included the use in applications requiring storage and serial transmission of configuration and control information. User can place address data into IADR register and set IEINTS to '1' (in IEX register) in advance. In the DDC1 mode (after clearing $\overline{\text{ENDDC}}$ to '0') and when the low level on the SCL pin

occurs, NT6861 will remind user by generating a INTS interrupt and switch to DDC2B mode automatically. When user sets MD1/2 to '1' at this time, the NT6861 will still proceed with a DDC1 communication. The DDC2B bus consists of two wires, SCL and SDA; SCL is for the data transmission clock and SDA is for the data line. Data transfers follow the format shown in Figure 19. The standard communication of I²C bus protocol includes four parts: a START signal, slave ADDRESS, transferred data (proceed byte by byte) and a STOP signal. In the wired-AND connection, any slow devices can hold the SCL line LOW to force the fast device into a wait state until the slow device is ready for the next bit or byte transfer in a type of handshake procedure.

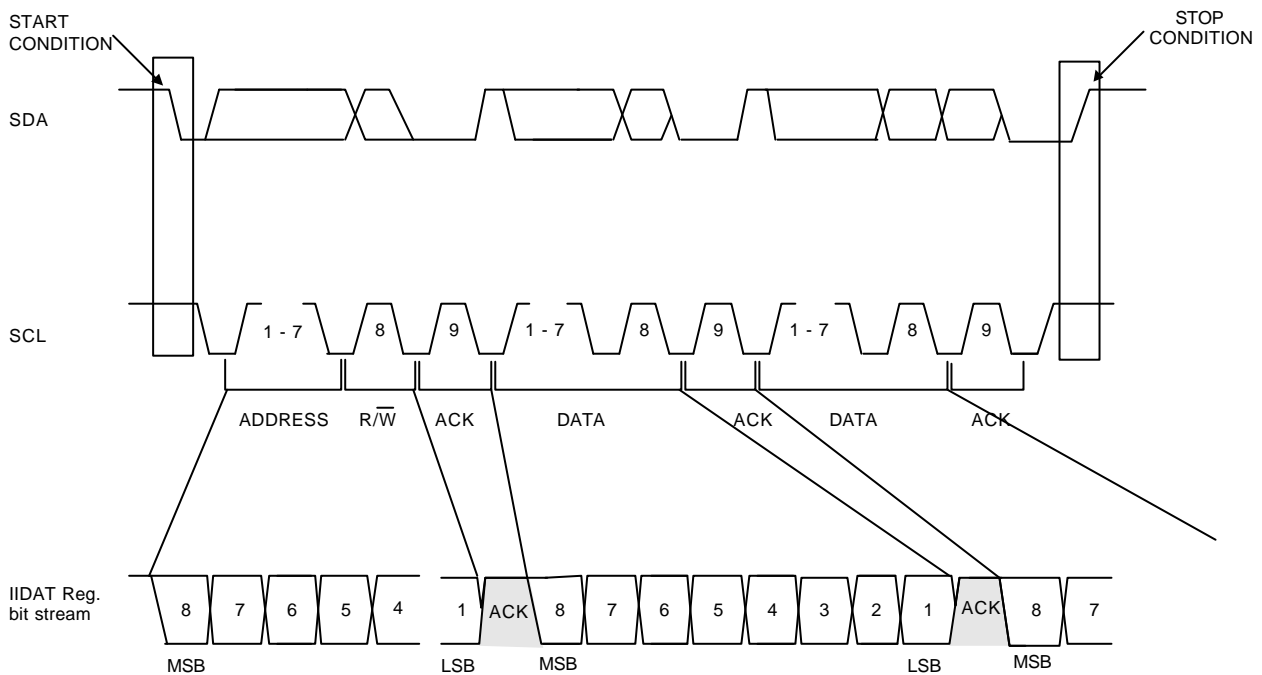

Figure 23. DDC2B Data Transfer

Start condition: When SCL & SDA lines are in HIGH state, an external device (master) may initiate communication by sending a START signal (defined as SDA from high to low transition while SCL is in high state). When there is a START condition, NT6861 will set the 'START' bit to '1' and user can poll this status bit to control DDC2B transmission at any time. This bit will keep '1' until user clears it. After sending a START signal for DDC2B communication, an external device can repeatedly send start conditions without sending a STOP signal to terminate this communication. This is used by the external device to communicate with another slave or with the same slave in different mode (READ or WRITE mode) without releasing the bus.

Address matched and INTA: After the START condition, a slave address is sent by external device. When I²C bus interface changes to DDC2B mode, NT6861 will first act as a receiver to receive this one byte data. This address data is 7 bits long followed by the eighth bit that indicates the data transfer direction (R/\overline{W}). When NT6861 system receives address data from external device, it will store it in IIDAT register. System support 'A0' address by default and another one set of DDC2 address for user. When user enable DDC2 function, the system will compare address data getting from external device with the default address 'A0' and data in the \$0013 II_ADR control register written by user. Either of these address matched, the system will generate an INTA interrupt flag and this DDC2 communication will be continued. If user sets IEINTA bit to '1' in advanced and address data matched, the NT6861 system will generate a INTA interrupt. Under the address matching condition, the NT6861 will send an acknowledgment to external device. If address data not matched, the NT6861 will not generate INTA interrupt and not care the data change on SDA line in the future.

Data Transmission direction: At INTA interrupt servicing routine, user must check the LSB of address data in IIDAT register. According to I²C bus protocol, this bit indicates the DDC2B data transfer direction in later transmission - a '1' indicates a request for 'READ MODE' action (external read data from system); a '0' indicates a 'WRITE MODE' action (external write data to system). For READ mode and WRITE mode timing diagram refer to Figure 24 and 25. The data transfer can be proceeded byte by byte in a direction specified by the R/\overline{W} bit after a successful slave address is received. User must set TRX bit in the IISTS register for NT6861 transmission mode - '1' for READ mode and '0' for WRITE mode.

Data validity and transfer: The data on the SDA line must be stable during the HIGH period of the clock on the SCL line. The HIGH and LOW state of the SDA line can only change when the clock signal on the SCL line is LOW. Each byte data is eight bits long and one clock pulse for one bit of data transfer. Data is transferred with the most significant bit (MSB) first. If a receiver (external device or NT6861) cannot receive another complete byte of data until it has performed some other function, for example servicing an internal interrupt, it can hold the clock line SCL LOW to force the transmitter into a wait state. Data transfer then continues when the receiver is ready for another byte of data and release clock line SCL. Each byte data is followed by an acknowledge bit.

Acknowledge: The acknowledgment will be generated at ninth clock by whom receive data. In the WRITE mode, NT6861 system must respond to this acknowledgment. After receiving one byte data from external device, NT6861 will automatically send an acknowledgment by pulling SDA line to 'LOW'. In the READ MODE, external device must respond to this acknowledgment and at every byte data sent, user can read RXAK bit in IISTS register to check if external sent a ACK or not.

The INTD interrupt: After NT6861 receive the START condition, it will generate an INTD interrupt at the falling edge of the ninth clock. User can control the flow of DDC2B transmission at this INTD interrupt.

The INTD on the WRITE mode: NT6861 read data from external device. At INTD interrupt, the SCL will be hold LOW by NT6861. When getting one byte data from II_DAT register, user can write '00' into II_DAT register and the SCL will be released. External device can continue sending next byte data to NT6861. Refer to Figure 24.

The INTD on the READ mode: External device read data from NT6861. At INTD interrupt, the SCL will be hold LOW by NT6861. User can check RXACK bit in the IISTS register whether external device has sent an ACK or not after one byte data transfer. If external device has sent an ACK, the RXACK will be '0' (assume the acknowledgment is LOW signal). When user puts one new byte data into II_DAT register, the SCL will be released for generation of SCL transmission clock. The next byte data will be shifted out properly. Refer to Figure 25.

STOP condition: When SCL & SDA lines have been released (remain in 'HIGH' state), DDC2B data transfer is always terminated by a STOP condition generated by external device. A STOP signal is defined as a low to high transition of SDA while SCL is in HIGH state. When there is a STOP condition, NT6861 will set the 'STOP' bit to '1' and user can poll this status bit to control DDC2B transmission at any time. This bit keeps '1' until user clears it. Notice the SCL and SDA lines must conform to I²C bus specifications. (Refer to Figure 26). Refer to the standard I²C bus specification for details.

Changing to DDC1 mode: After an external device terminates DDC2 transmission, set MD1/ $\bar{2}$ to 1 for changing to DDC1 mode. When the SCL line has been released (pulled-up), user can force NT6861 to DDC1 mode communication at any time. This function is supporting the 'error' recovery protocol in the VESA DDC standard Ver 2.0.

Control bit description:

Addr.	Register	INIT	Bit7	Bit6	Bit5	Bit4	Bit3	Bit2	Bit1	Bit0	
\$0005	MD CON	07H	- -	- -	- -	- -	- INSEN	- HSEL	S/ \bar{C} S/ \bar{C}	MD1/ $\bar{2}$ MD1/ $\bar{2}$	R W
\$000F	IEX	00H	-	-	IEINTS	IEINTD	IEINTA	IEINTR	IEINTE	IEINTV	W
\$0010	IRQX	00H	-	-	IRQINTS	IRQINTD	IRQINTA	IRQINTR	IRQINTE	IRQINTV	R
\$0011	CLR FLG	00H	CLRHOV	CLRVOV	CLRINTS	CLRINTD	CLRINTA	CLRINTR	CLRINTE	CLRINTV	W
\$0013	II ADR	FFH	AR7	AR6	AR5	AR4	AR3	AR2	AR1	-	W
\$0014	II DAT	00H	SR7	SR6	SR5	SR4	SR3	SR2	SR1	SR0	RW
\$0015	II STS	08H	-	-	START START	STOP STOP	$\overline{\text{ENDDC}}$	TRX	RXAK	-	R W

MDCON control register:

MD1/ $\bar{2}$: Select the DDC mode - '1' for DDC1 and '0' for DDC2B mode. System will be DDC1 mode by default. When transmission mode is changed from DDC1 to DDC2B, system will automatically clear this bit.

IEX control register:

In DDC2 mode, user use INTS, INTA & INTD interrupt and II_STS control register to control DDC2B transmission.

II_DAT control register: Data buffer for transmission

II_ADR control register: User can define the address of DDC2B device. If an external device sends the same address data as this control register (calling NT6861), NT6861 will generate an INTA interrupt.

II_STS control register:

$\overline{\text{ENDDC}}$: When clearing this bit, the system will activate DDC transmission. P30 and P31 will switch to SDA and SCL pin.

TRX: In the READ mode of DDC2B transmission, user must set this bit '1'.

RXAK: In the WRITE mode of DDC2B transmission, after one byte has been sent out to the SDA line, there will be an INTD interrupt. At INTD interrupt service routine, user can check this bit to see if external device has responded to NT6861.

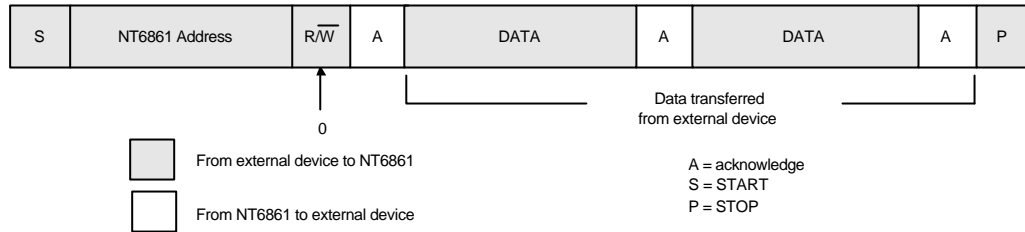

(a) WRITE_Mode Data Format

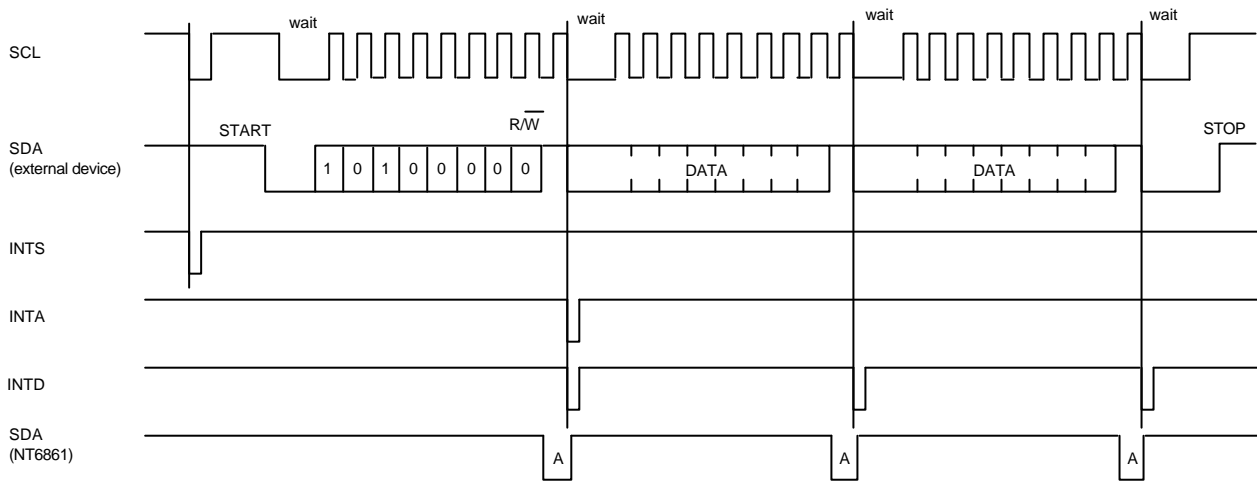

(b) WRITE_Mode timing Diagram

Figure 24. DDC2B Write_Mode Spec.

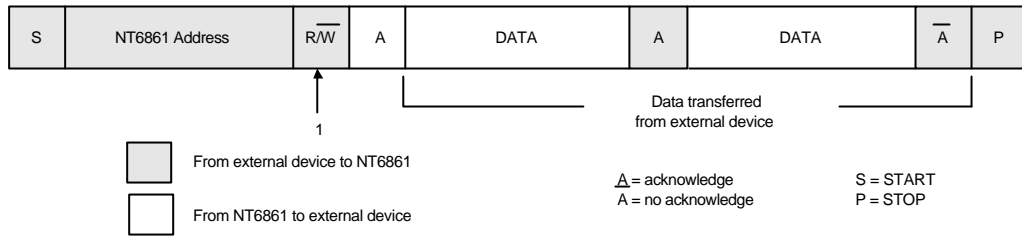

(a) Read_Mode Data Format

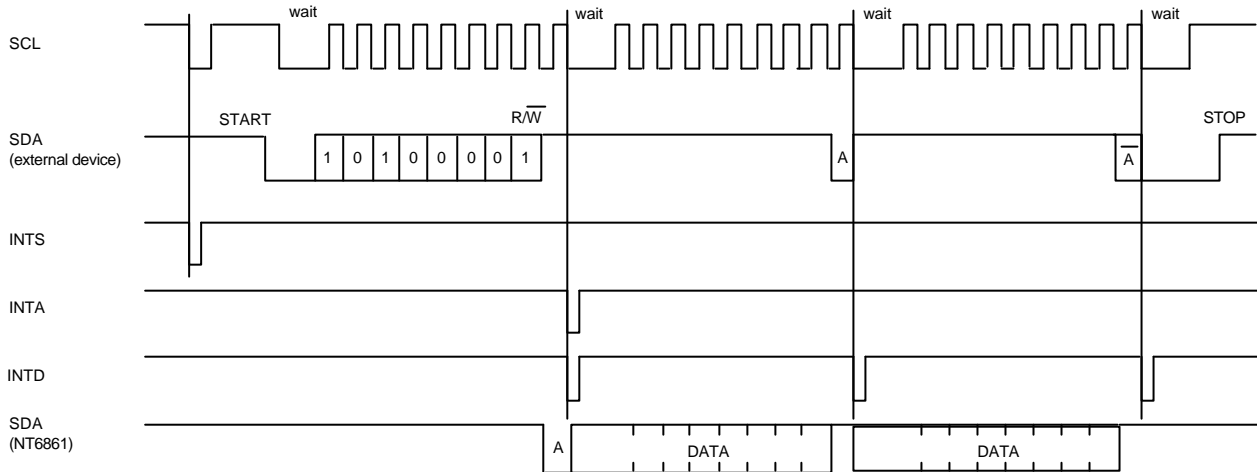

(b) READ_Mode timing Diagram

Figure 25. DDC2B Read_Mode Spec.

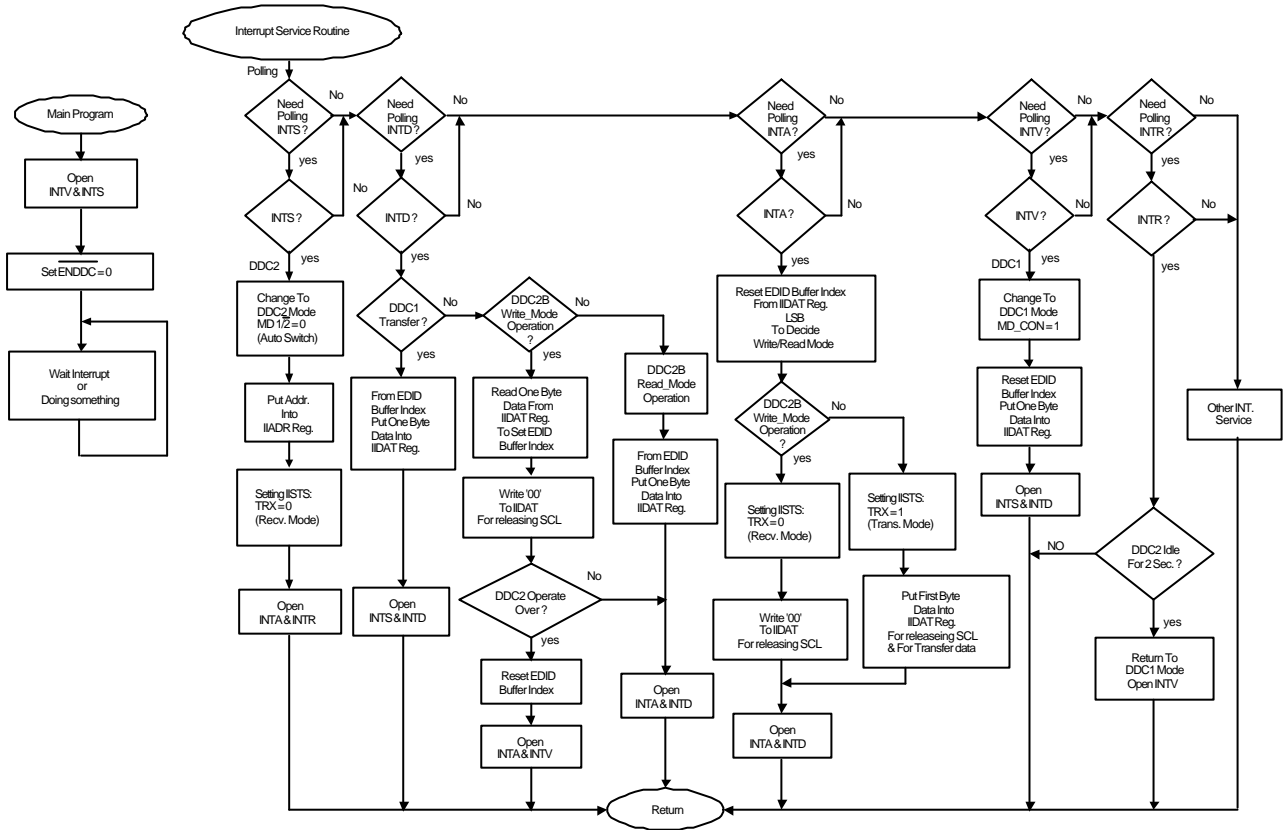

Figure 26. DDC1/2B Software Flow Chart

Absolute Maximum Ratings*

DC Supply Voltage $V_{DD} - V_{SS}$ -0.3V to 7V
 Input Voltage GND -0.2V to $V_{CC} + 0.2V$
 Operating Temperature 0°C to +70°C
 Storage Temperature -50°C to +125°C

***Comments**

Stresses above those listed under "Absolute Maximum Ratings" may cause permanent damage to this device. These are stress ratings only. Functional operation of this device at these or any other conditions above those indicated in the operational sections of this specification is not implied or intended. Exposed to the absolute maximum rating conditions for extended periods may affect device reliability.

DC Electrical Characteristics ($V_{DD} = 5V$, $T_A = 25^\circ C$, oscillator freq. = 8MHz, unless otherwise specified)

Symbol	Parameter	Min.	Typ.	Max.	Unit	Conditions
I_{DD}	Operating Current			20	mA	No loading
VIH1	Input High Voltage	2			V	P00 - P07, P10-P16, P20-P27, P30, P31, \overline{RESET} , VSYNCl, HSYNCl, HALFHI, INTE
VIH2	Input High Voltage	3			V	SCL, SDA pins
VIL1	Input Low Voltage			0.8	V	P00 - P07, P10 - P16, P20 - P27, P30, P31, \overline{RESET} , VSYNCl, HSYNCl, HALFHI, INTE
VIL2	Input Low Voltage			1.5	V	SCL, SDA pins
IiH	Input High Current		-200	-350	μA	P00 - P07, P10 - P16, P20 - P27, VSYNCl, HSYNCl, HALFHI, \overline{RESET} ($V_{IH} = 2.4V$)
VOH1	Output High Voltage	2.4			V	P00 - P07, P10 - P15 ($I_{OH} = -100\mu A$) VSYNCO, HSYNCO ($I_{OH} = -4mA$) HALFHO ($I_{OH} = -4mA$) P20-P27 ($I_{OH} = -10mA$)
VOH2	Output High Voltage (DAC8 - DAC13)			5	V	external applied voltage
VOH3	Output High Voltage (DAC0 - DAC7)			12	V	external applied voltage
VOL	Output Low Voltage			0.4	V	P00 - P07, P10 - P15, DAC0 - 13 ($I_{OL} = 4mA$) SCL/P30, SDA/P31 ($I_{OL} = 5mA$) VSYNCO, HSYNCO ($I_{OL} = 4mA$) HALFHO ($I_{OL} = 4mA$) P20 - P27 ($I_{OL} = 10mA$)
ROL	Pull Down Resistor (\overline{RESET})	25K	50K	75K	Ω	
ROH1	Pull Up Resistor (INTE)	11K	22K	33K	Ω	
ROH2	Pull Up Resistor (PORT0 & PORT1)	11K	22K	33K	Ω	
ROH3	Pull Up Resistor (HSYNCl & VSYNCl)	11K	22K	33K	Ω	

AC Electrical Characteristics ($V_{DD} = 5V$, $T_A = 25^\circ C$, oscillator freq. = 8MHz, unless otherwise specified)

Symbol	Parameter	Min.	Typ.	Max.	Unit	Condition
Fsys	System Clock		8		MHz	
t _{CNV}	A/D Conversion time			375	μs	
Voffset	A/D Converter Offset Error			39	mV	V _{in} = 2V for A/D converter
Vlinear	A/D Input Dynamic Range of Linearity conversion	0.3		0.7	V _{DD}	
tinst	The inserted Hsync pulse width		2		μs	Composite sync (Refer Figure 18)
tdev	The time deviation at the end edge of inserted Hsync pulse			250	ns	Composite mode & insertion function activated
t _{RESET}	Reset Pulse Width Low	2			t _{CYCLE}	t _{CYCLE} = 2/Fsys
Fvsync	Vsync Input Frequency	32		25K	Hz	t _{VSYNC} = 1/Fvsync
t _{VPW}	Vsync Input Pulse Width	8		300	μs	
Fhsync	Hsync Input Frequency	30		120	KHz	t _{HSYNC} = 1/Fhsync
t _{HPW1}	Hsync Input Pulse Width High	0.5		7	μs	
t _{HPW2}	Hsync Input Pulse Width Low	8			μs	Composite sync
t _{ERROR1}	Counting Deviation of Base Timer			1	μs	1μs clock source
t _{ERROR2}	Counting Deviation of Base Timer			1	ms	1ms clock source

DDC1 Mode

Symbol	Parameter	Min.	Typ.	Max.	Unit	Condition
t_{VPW}	Vsync high time	0.5		300	us	
F_{vsync}	Vsync Input Frequency	32		25K	Hz	$t_{VSYNC} = 1/F_{vsync}$
t_{DD}	Data valid	200		500	ns	
t_{MODE}	Time for transition to DDC2B mode			500	ns	

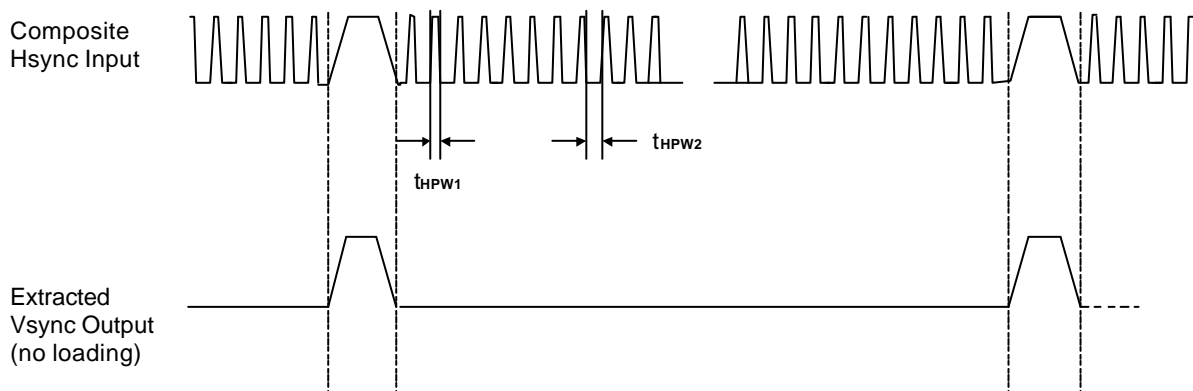
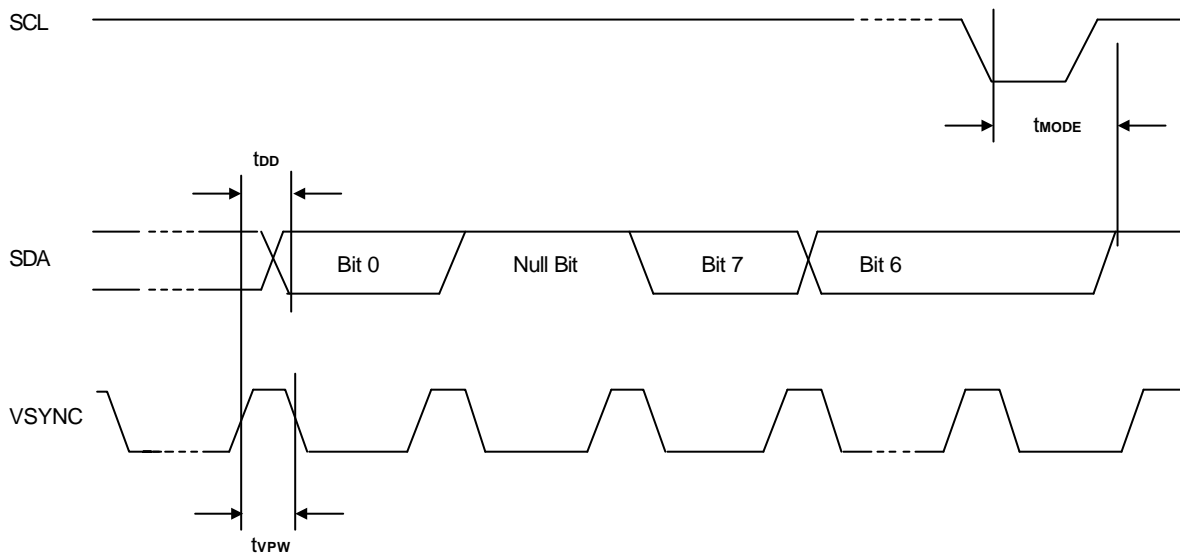

DDC2B Mode

Symbol	Parameter	Min.	Typ.	Max.	Unit
fSCL	SCL Clock Frequency			100	KHz
t _{BUF}	Bus Free Between a STOP and START Condition	4.7			μs
t _{HD; STA}	Hold Time for START Condition	4			μs
t _{LOW}	LOW Period of the SCL Clock	4.7			μs
t _{HIGH}	HIGH Period of the SCL Clock	4			μs
t _{SU; STA}	Set-up Time for a Repeated START Condition	4.7			μs
t _{HD; DAT}	Data Hold Time	300			ns
t _{SU; DAT}	Data Set-up Time	300			ns
t _R	Rise Time of Both SDA and SCL Signals			1	μs
t _F	Fall Time of Both SDA and SCL Signals			300	ns
t _{SU; STO}	Set-up Time for STOP Condition	4			μs

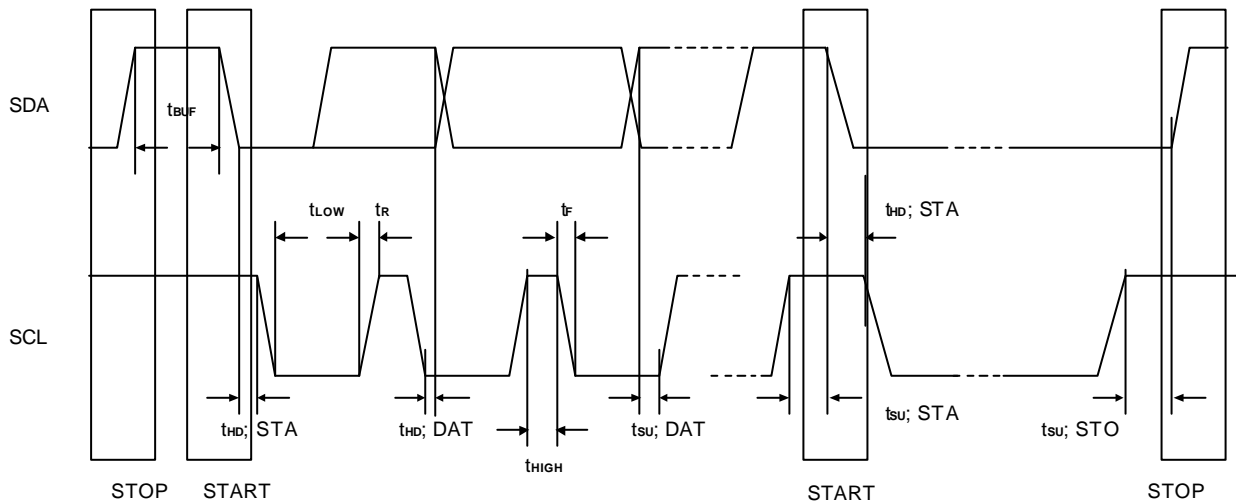

Ordering Information

Part No.	Package
NT6861	40L DIP
NT6861U	42L S-DIP

Package Information
DIP 40L Outline Dimensions

unit: inches/mm

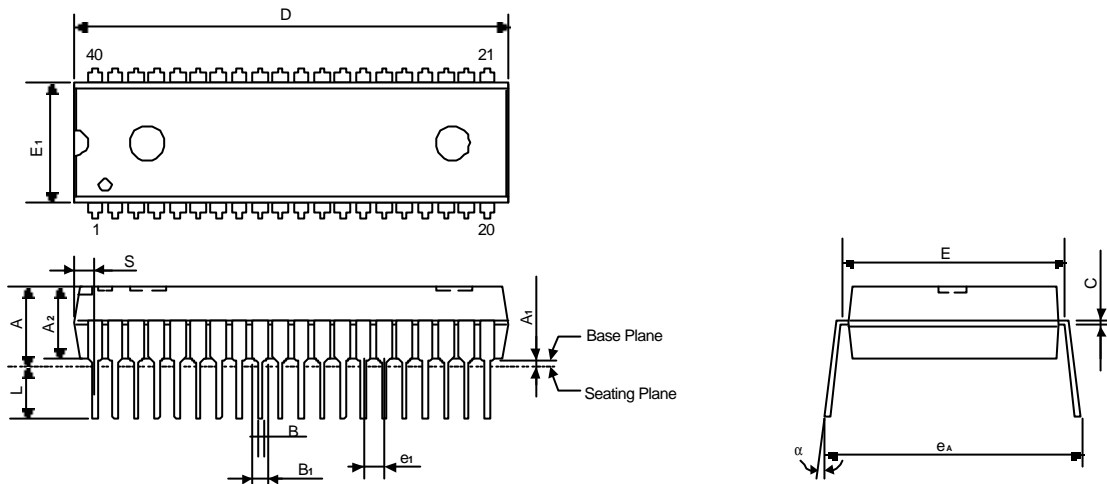

Symbol	Dimensions in inches	Dimensions in mm
A	0.210 Max.	5.33 Max.
A1	0.010 Min.	0.25 Min.
A2	0.155 ± 0.010	3.94 ± 0.25
B	0.018 +0.004 -0.002	0.46 +0.10 -0.05
B1	0.050 +0.004 -0.002	1.27 +0.10 -0.05
C	0.010 +0.004 -0.002	0.25 +0.10 -0.05
D	2.055 Typ. (2.075 Max.)	52.20 Typ. (52.71 Max.)
E	0.600 ± 0.010	15.24 ± 0.25
E1	0.550 Typ. (0.562 Max.)	13.97 Typ. (14.27 Max.)
e1	0.100 ± 0.010	2.54 ± 0.25
L	0.130 ± 0.010	3.30 ± 0.25
α	0° ~ 15°	0° ~ 15°
ea	0.655 ± 0.035	16.64 ± 0.89
S	0.093 Max.	2.36 Max.

Notes:

1. The maximum value of dimension D includes end flash.
2. Dimension E1 does not include resin fins.
3. Dimension S includes end flash.

Package Information
S-DIP 42L Outline Dimensions

unit: inches/mm

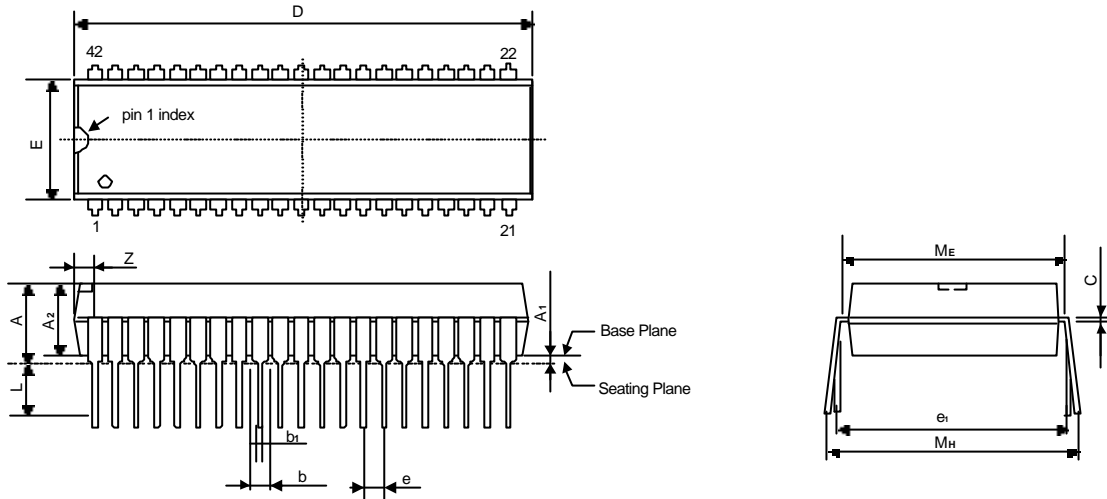

Symbol	Dimensions in inches	Dimensions in mm
A	0.200 Max.	5.08 Max.
A1	0.020 Min.	0.51 Min.
A2	0.157 Max.	4.0 Max.
b	0.051 Max. 0.031 Min.	1.3 Max. 0.8 Min.
b1	0.021 Max. 0.016 Min.	0.53 Max. 0.40 Min.
c	0.013 Max. 0.010 Min.	0.32 Max. 0.23 Min.
D ⁽¹⁾	1.531 Max. 1.512 Min.	38.9 Max. 38.4 Min.
E ⁽¹⁾	0.551 Max. 0.539 Min.	14.0 Max. 13.7 Min.
e	0.070	1.778
e1	0.600	15.24
L	0.126 Max. 0.114 Min.	3.2 Max. 2.9 Min.
ME	0.622 Max. 0.600 Min.	15.80 Max. 15.24 Min.
MH	0.675 Max. 0.626 Min.	17.15 Max. 15.90 Min.
w	0.007	0.18
Z ⁽¹⁾	0.068 Max.	1.73 Max.

Notes:

1. Plastic or metal protrusions of 0.25 mm maximum per side are not included.